



**YOUR SAFETY
FIRST!**

Read this booklet
carefully before
installing your door



**HEAVY -
LIFT WITH
CAUTION!**

**Garage™
DOOR SYSTEMS**

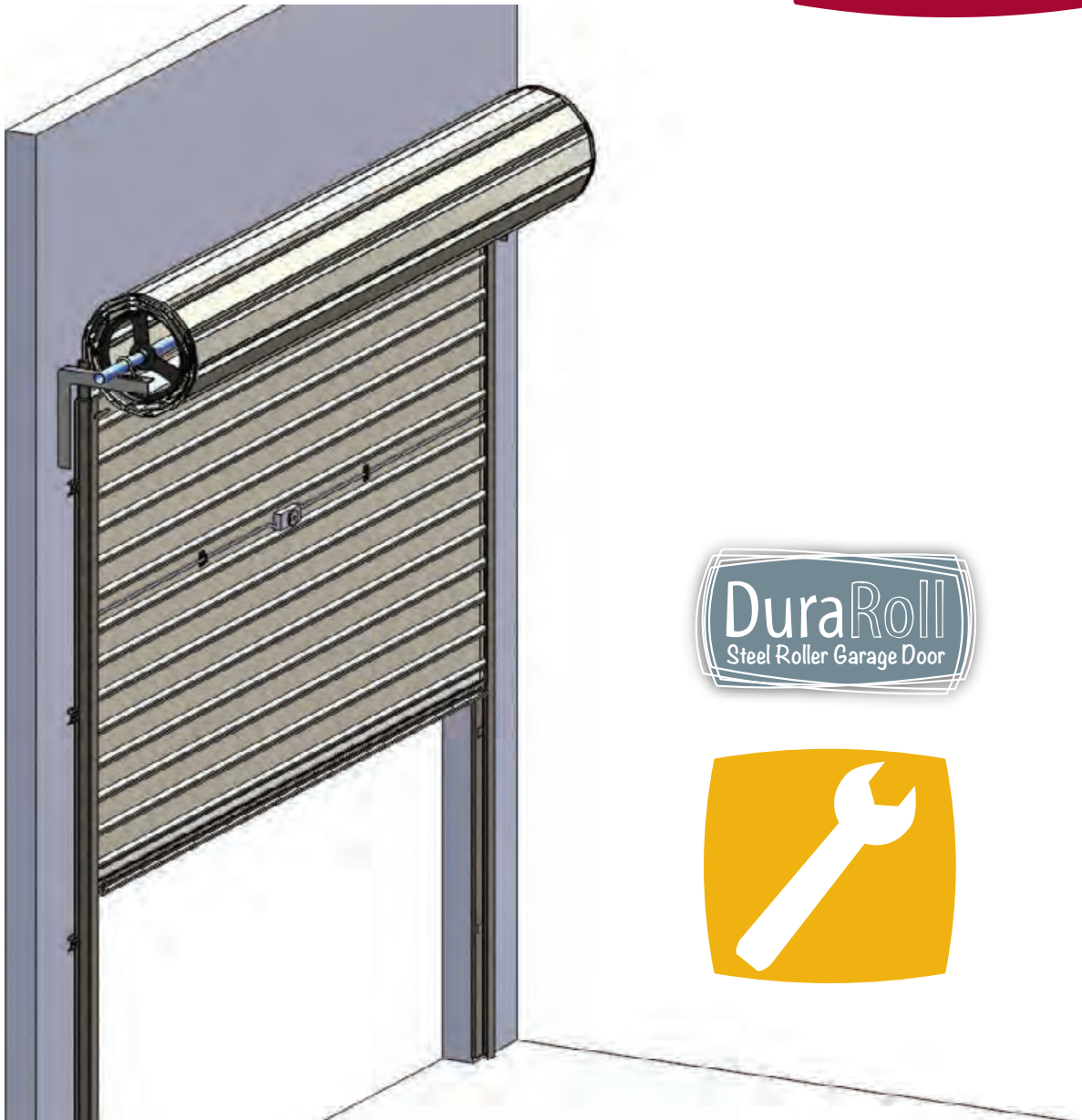

DuraRoll
Steel Roller Garage Door



DuraRoll & DuraRoll Mini

DuraRoll Roller Garage Door

2016 V1

Installation Instructions

For residential single and double size doors



This new GDS door has been designed for ease of operation, security and attractive appearance with minimal maintenance. Performance of the door will be impaired if it is installed incorrectly. **Read these instructions carefully before commencing the installation. Warranty is void if the door is not installed correctly according to these instructions.**



WARNING! FRAGILE!

PRE-INSTALLATION CARE AND HANDLING

- The door curtain must be handled with care at all times
- The doors length must be supported in its entirety during transport and handling
- The door must be stored on a flat **DRY** surface
- **Packaging must not be removed until instructed (at the correct step in the installation)**



WARNING!

Ensure that the area around the opening is strong enough to support the door.

GENERAL NOTES

Both one and two-car doors are installed in the same manner.

Be sure all warning labels and tags are properly affixed to the door and that the home owner information is left with the purchaser.

SAFETY EQUIPMENT

Goggles
Safety Shoes
Gloves



WHO SHOULD INSTALL THIS DOOR?

A minimum of two people must be available for fitting. However due to the weight and spring tension of larger doors, we insist that three people or suitable lifting gear be available for installation **on doors over 10ft wide or 9ft high.**

















KEYPOINTS: ELECTRICALLY OPERATED DOORS

Please read the instructions relating to the installation of an electric motor prior to commencing. Key guidance is summarised here and repeated at the relevant step in the installation.

- The installed door must operate efficiently when used manually. Ensure sufficient clearance between door and bracket to facilitate fitting of motor (See Side Clearance, page 4).
- Turn off the power before making any adjustments.
- Make sure the anti-coning collar is adjusted and secure on the drum shaft to eliminate sideways movement on the opposite side to which motor is to be fitted.
- When installing the door, ensure the motor is disengaged and the drum turns freely.
- Never engage the manual release with motor running.
- The upper limit on the operator should be set to stop the roller door, 30-40mm below the guide stop, to avoid damaging the drive gears.
- Weight bar must be attached to bottom bar with rivets/bolts.

TOOLS REQUIRED FOR INSTALLATION



-  Tape measure
-  Stanley knife
-  Pencil
-  Spirit level
-  8, 13 & 17mm sockets
-  8mm spanner
-  Masonry drill
-  Electric drill
-  'A' rated steps x2
-  Drill bit 10mm masonry
13mm steel bit
-  Square file
-  Two 18" pipe wrenches
-  Hammer
-  Screw drivers
-  Hacksaw

THE PACKED DOOR



DO NOT REMOVE ANY WRAPPING UNTIL INSTRUCTED*

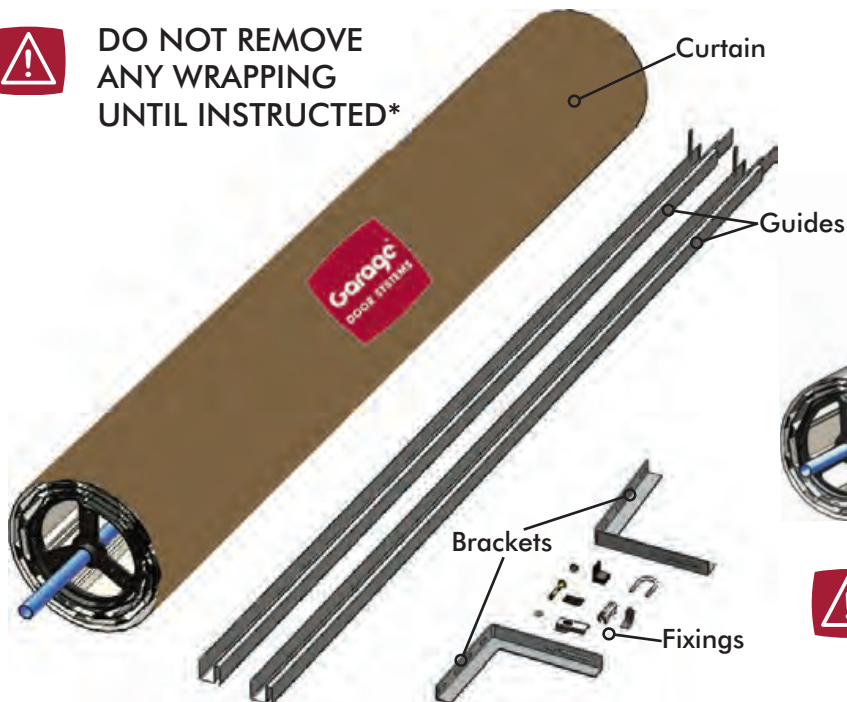

***STEEL OUTER WRAPPING CAN BE REMOVED IF PRESENT**



CHECK FOR OBVIOUS SIGNS OF DAMAGE AND REFER TO WARNING LABEL



STRUCTURAL CONDITIONS OF OPENING:

The surface where the door is to be fitted must be flush and reasonably smooth. Small irregularities in brick work will be acceptable. The lintel must not protrude backwards or forwards from the brick piers.

BEFORE YOU START: OPENING SIZE

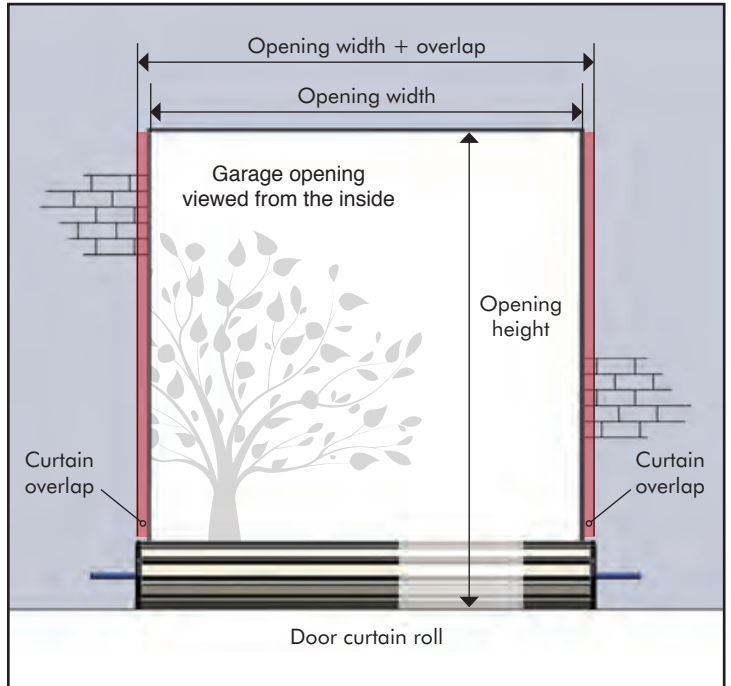
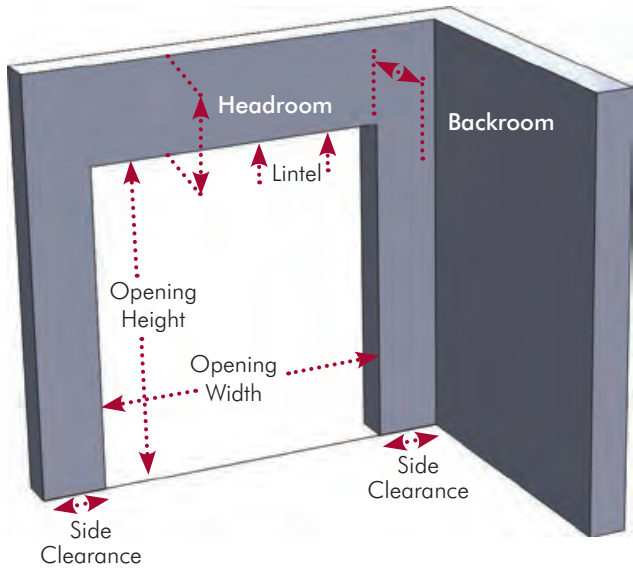

OPENING WIDTH:

DuraRoll garage doors fit behind the garage opening. Check that the door curtain supplied overlaps the opening width at each side by the minimum requirements:

Door curtain size	Guide size	Overlap each side	
Up to 2896mm (9'6") wide & 2438mm (8'0") high	30mm ^a	25mm ^a	✓
Over 2896mm (9'6") wide & 2438mm (8'0") high	50mm	50mm	✓

^aIn Ireland all door sizes are supplied with 50mm guides

OPENING HEIGHT:

The door will fit any opening height up to that stated on the packaging, e.g. a 2134mm high door can be fitted to a 2000mm high opening

BEFORE YOU START: SIDE CLEARANCE

How much room do I need at the side of the garage opening?

The door is mounted onto brackets and the brackets must be set in from the side of the garage opening by the minimum distance to the outside edge of the bracket as shown in the table below.

Doors with a motor require extra clearance on the side the motor is fitted - see table below.

To achieve the minimum side clearance you will need to cut the ends of the door axle.

Door curtain size	Guide size	Side clearance for manual doors	Side clearance for doors with a motor
-------------------	------------	---------------------------------	---------------------------------------

STANDARD DOORS

Up to 2896mm (9'6") wide & 2438mm (8'0") high	30mm ^a	95mm ^a each side	135mm ^a motor side 95mm non-motor side	✓
Over 2896mm (9'6") wide & 2438mm (8'0") high	50mm	120mm each side	160mm motor side 120mm non-motor side	

MINI DOORS

Up to 2896mm (9'6") wide	30mm ^a	95mm ^a each side	165mm ^a motor side 95mm non-motor side	✓
Over 2896mm (9'6") wide	50mm	120mm each side	190mm motor side 120mm non-motor side	

^aIn Ireland all door sizes are supplied with 50mm guides

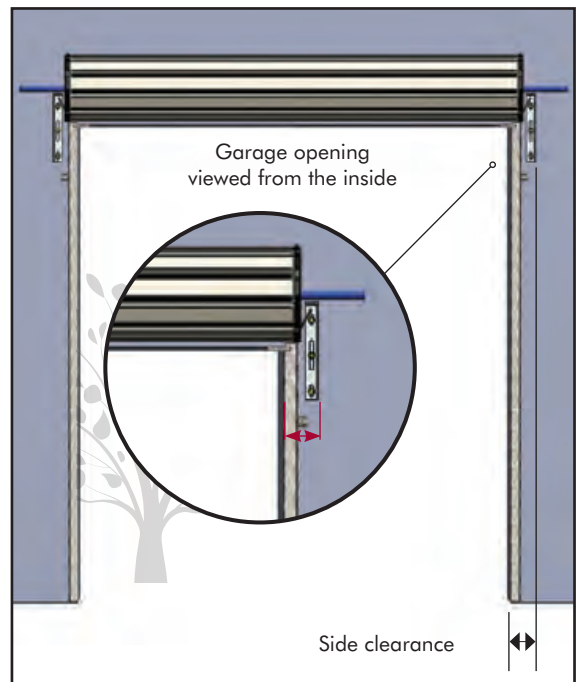

BEFORE YOU START: BACKROOM

How much room do I need behind the garage opening?

The door curtain is mounted on brackets above the garage opening and projects back into the garage. The door will require the minimum backroom as shown:

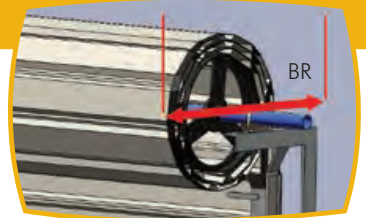

STANDARD DOORS

Door curtain size	Guide size	Minimum backroom
All door sizes	30mm or 50mm	495mm



MINI DOORS

Door curtain size	Guide size	Minimum backroom
All door sizes	30mm or 50mm	390mm



BEFORE YOU START: HEADROOM

How much room do I need above the garage opening?

The door curtain is mounted on brackets above the garage opening and to allow maximum drive through height, the minimum headroom required is shown in the table below.

If insufficient headroom is available to allow the door roll to be fitted fully above the opening, the door may be fitted projecting down into the opening up to a maximum of 100mm without the need for a fascia. If the door projects down by more than 100mm a fascia (not supplied) will be required - see figure 1.

Note: 10mm more headroom is required to install the door than is needed to operate the door once installed. If the available headroom is right at the minimum, the bracket can be fixed 10mm lower whilst the door roll is fitted and tensioned and then tapped up by 10mm once the door is installed to give full clearance with no hangdown.

Door curtain size	Minimum headroom
-------------------	------------------

STANDARD DOORS

Up to 2438mm (8'0") high	431mm* / 441mm**
Over 2438mm (8'0") high & up to 3048mm (10'0") high	483mm / 493mm**



MINI DOORS

Up to 2134mm (7'0") high	343mm* / 353mm**
--------------------------	------------------



*The minimum headroom but will require bracket position adjustment during installation to achieve full opening height. (see page 9)

**The minimum headroom that requires no bracket position adjustment during installation to achieve full opening height. (see page 9)

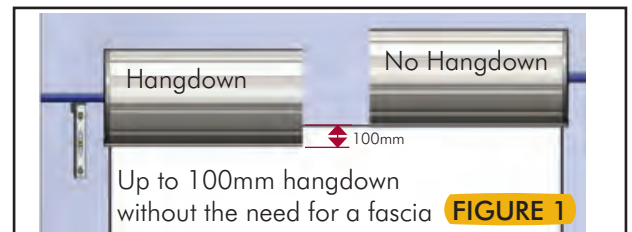
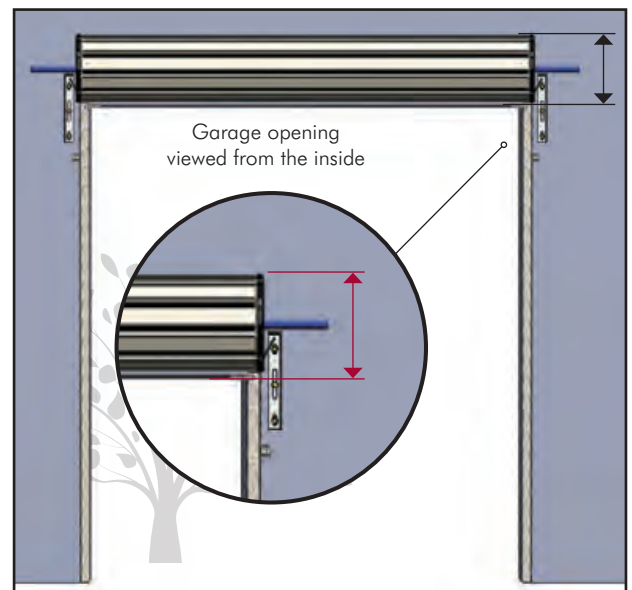

Up to 100mm hangdown without the need for a fascia **FIGURE 1**

BEFORE YOU START: FITTING NOTES

Do not remove any wrapping, or steel protective outer wrapping if fitted to your door, until instructed.

- Door package and its contents should be checked for obvious damage before removal of protective outer wrapping (If on your door).
- The door should only be fitted after any plastering of the area has been completed. Plaster splashes will damage the pre-finish on the curtain and cause premature wear of the nyloflex within the guides.
- The door must be fitted square and level irrespective of the shape of the opening. On no account should any compensation be made to suit an irregular opening

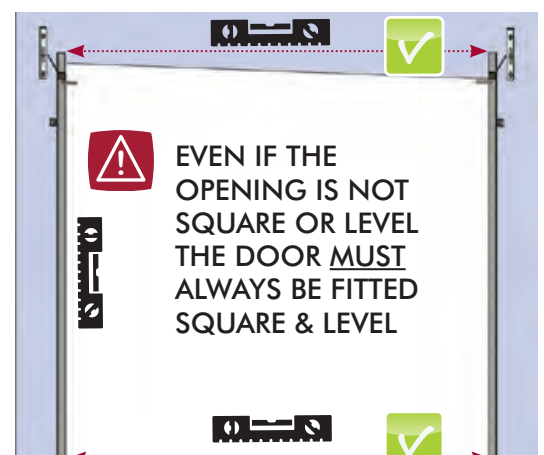

COMPONENTS

F 1x UN

Axle U-Bolt & 2x Flange Nuts



E 1x UN

Axle Saddle

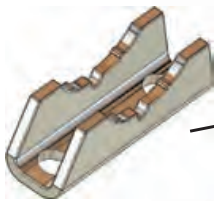

B 1x L

Bracket

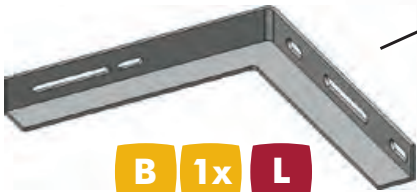

L

D 4x UN

Guide Lug



G 1x UN

Lock Hole Protective Cover

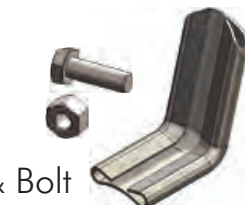

H 1x UN

Curtain Stop, Nut & Bolt



C 1x L

Left Guide

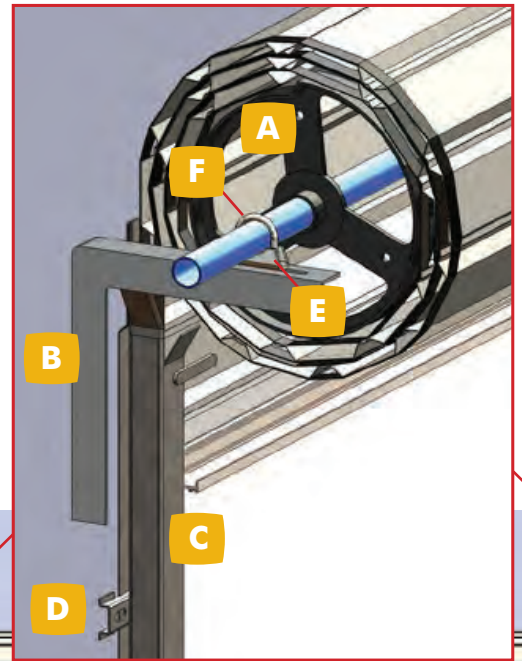
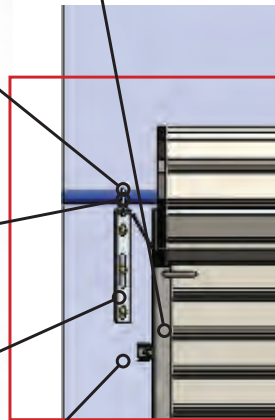



FIXINGS LIST



Your door will be supplied either with sleeve anchors or coach screws and plugs (both types are suitable for fitting DuraRoll doors)

M10 x 65mm
Sleeve anchor
Hex nut with
washer

1
x14



OR

2

M10 x 50
Blue wall
plugs



x14

M8 x 45mm
coach screws



x14

22mm
washer



R

KEY

Parts are handed (to fit on the left or right side of the door) or unhandled (fitting to either left or right side of the door). Any reference to handing - left or right assumes you are viewing the door from the inside. Items are not shown to scale for clarity.

UN Universal (unhandled)

LR Handed - marked with L (left) or R (Right)

Mark door position and fix brackets

TOOLS REQUIRED

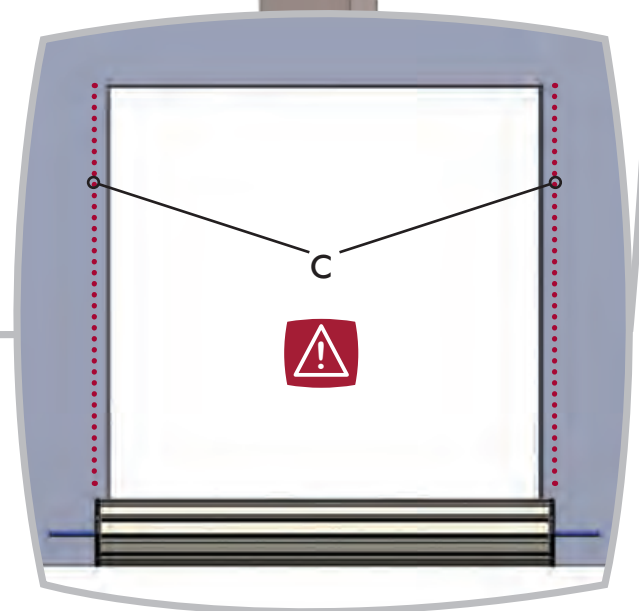
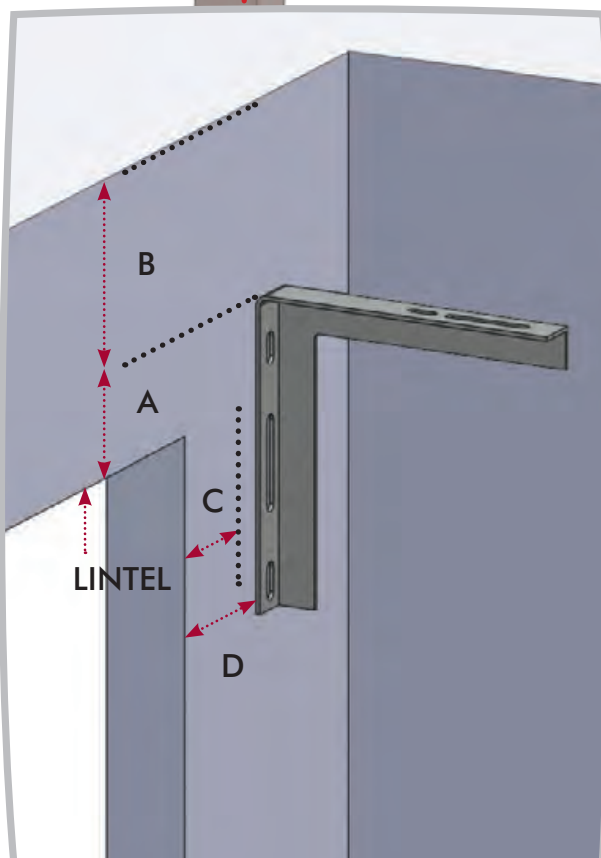
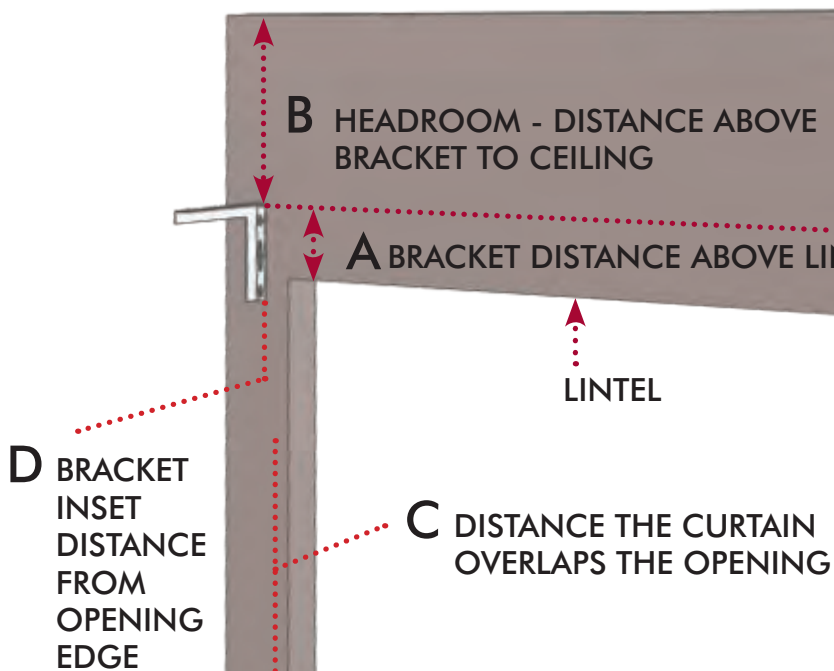

Mark the door curtain overlaps on the wall - 'C'

Check that the door curtain supplied overlaps the opening width at each side by the minimum requirements:

C=25mm each side for 30mm guides

C=50mm each side for 50mm guides

FIXINGS REQUIRED



Mark the fixing position of the bracket

STANDARD DOOR

Distance from the bottom of the lintel to the top of the bracket:

$A=200\text{mm}$

Minimum headroom above the bracket

$B=231\text{mm}^*$ (doors up to 8'0"/2438mm high)

$B=283\text{mm}^*$ (doors over 8'0"/2438mm high)

For the full height of the opening to be available

$A+B=431\text{mm}^*$ (doors up to 8'0"/2438mm high)

$A+B=483\text{mm}^*$ (doors over 8'0"/2438mm high)

If the full headroom is not available ($A+B=431\text{mm}/483\text{mm}$), the bracket can be fixed $241\text{mm}^*/293\text{mm}^*$ below the ceiling with the door curtain projecting down into the opening by up to a maximum of 100mm when fully open without the need for a fascia - see page 5 for detail drawings.

The minimum distance from the edge of the opening to the bracket is:

$D=$ Curtain overlap (C) + 10mm min

$D=$ Curtain overlap (C) + 185mm max

MINI DOOR

$A=140\text{mm}$ from the bottom of the lintel to the top of the bracket

$B=203\text{mm}^*$ minimum headroom above the bracket

$A+B=343\text{mm}^*$ for the full height of the opening to be available with the door fully open

If the full headroom is not available ($A+B=343\text{mm}$), the bracket can be fixed 213mm below the ceiling with the door curtain projecting down into the opening by up to a maximum of 100mm when fully open without the need for a fascia.

The minimum distance from the edge of the opening to the bracket is:

$D=$ Curtain overlap (C) + 10mm min

$D=$ Curtain overlap (C) + 185mm max

*Note: 10mm more headroom is required to install the door than is needed to operate the door once installed. If the available headroom is right at the minimum, the bracket can be fixed 10mm lower whilst the door roll is fitted and tensioned and then tapped up by 10mm once the door is installed to give full clearance with no hangdown. If this is the case, fix the brackets through the slotted holes (step 1) to allow for tapping up once the door roll is installed.

PARTS REQUIRED

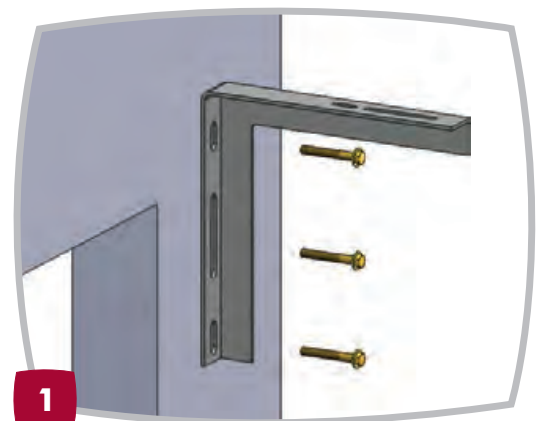

Fix the brackets in place at each side of the opening.

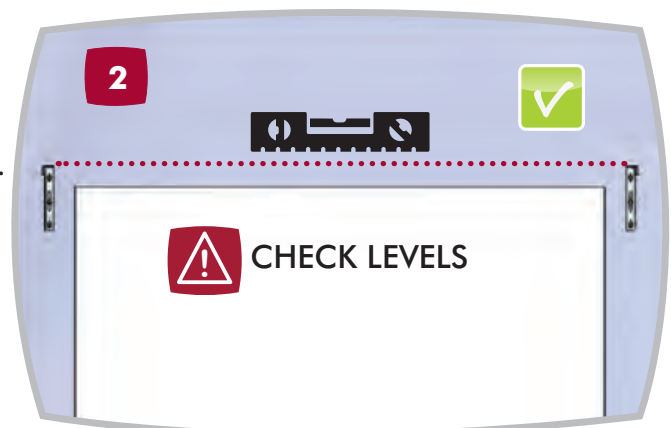

Prepare the guides

⚠ FOR THE CORRECT OPERATION OF THE DOOR, THE GUIDES MUST BE FITTED IN THE POSITIONS ILLUSTRATED BELOW.

STANDARD DOOR FULL HEADROOM AVAILABLE

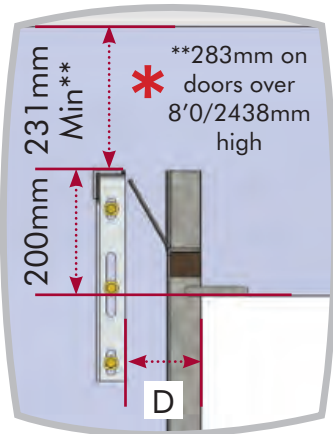

D=35mm Minimum on doors with 30mm guides
D=60mm Minimum on doors with 50mm guides

MINI DOOR FULL HEADROOM AVAILABLE

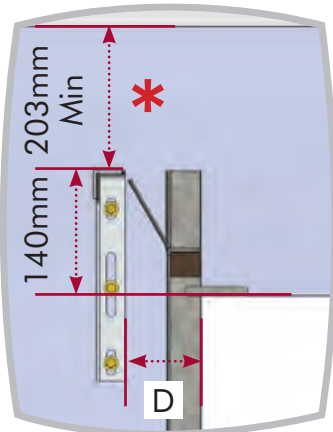

D=35mm Minimum on doors with 30mm guides
D=60mm Minimum on doors with 50mm guides

The distance shown from the top of the bracket to the ceiling is the minimum required for the door to operate once installed - 10mm additional space is required to install the door - see the note at the foot of page 9.

STANDARD DOOR RESTRICTED HEADROOM AVAILABLE

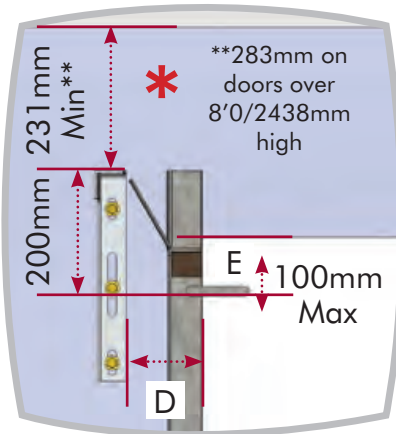

MINI DOOR RESTRICTED HEADROOM AVAILABLE

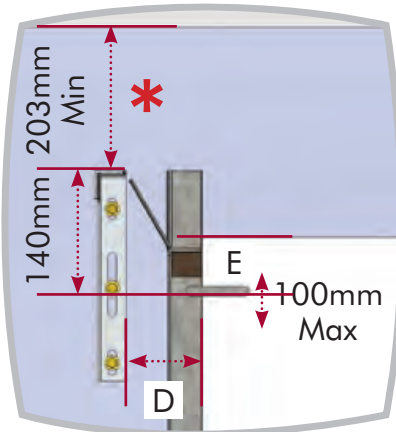

Cutting the guides to length:

Measure down from the top of the wall bracket by:

F=200mm for Standard Doors

F=140mm for Mini Doors

Mark the wall. Measure from this point to the finished floor level.

Transfer measurement (G) to the guide measuring from the bottom of the stop bar.

Shorten the guide to the required length.

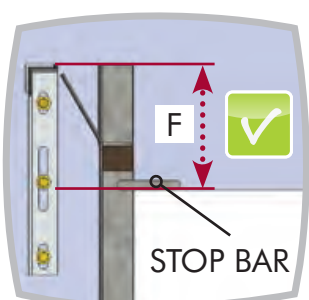
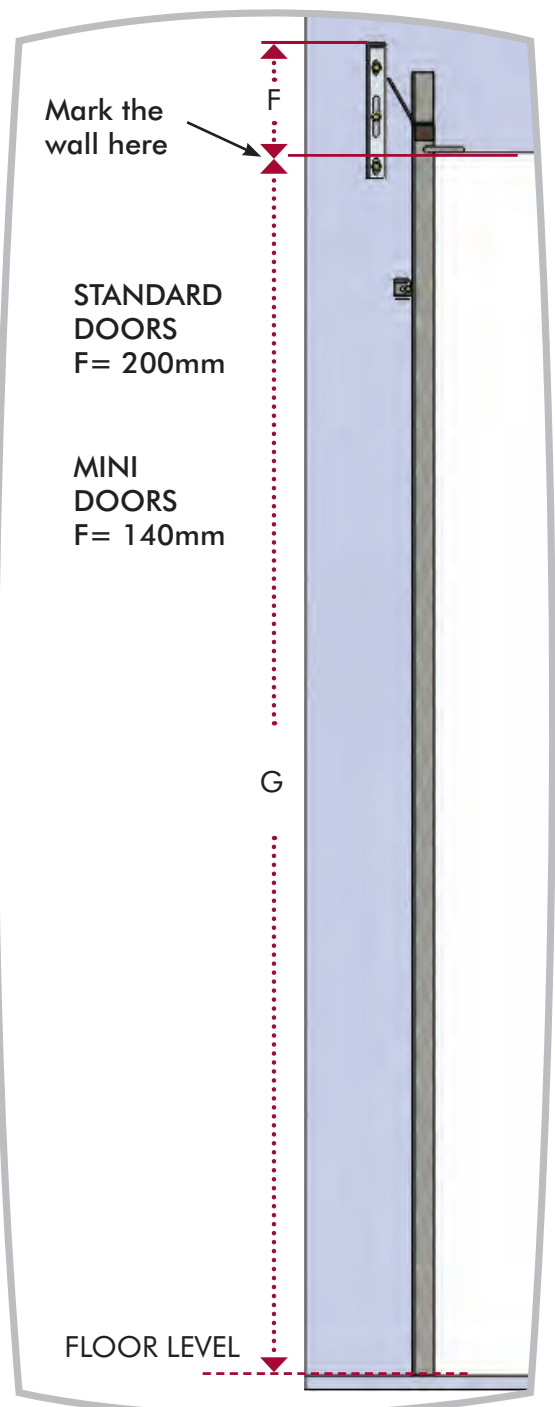

For automatic installations the measurement from the top of the horizontal leg of the support bracket to the bottom edge of the stop bar is critical. It must never be less than:

F=200mm Standard doors

F=140mm Mini doors

PARTS REQUIRED



1

Splay the guides creating a 3 sided funnel effect, it is critical to (if not already done so) to hammer flat the top 6" section that is exposed by the top notch.

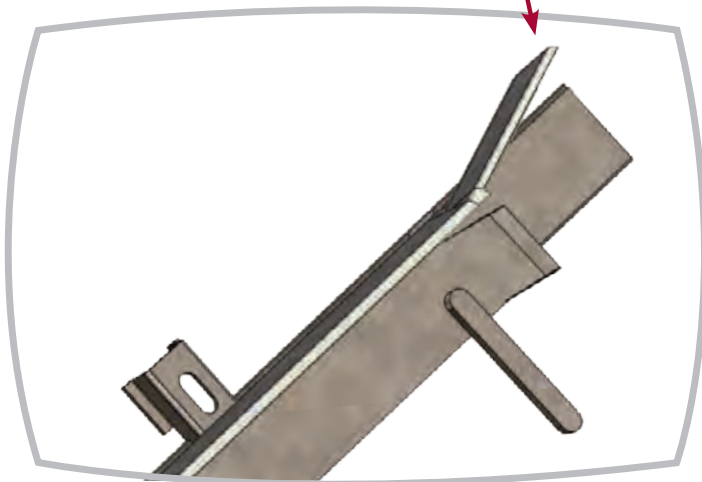
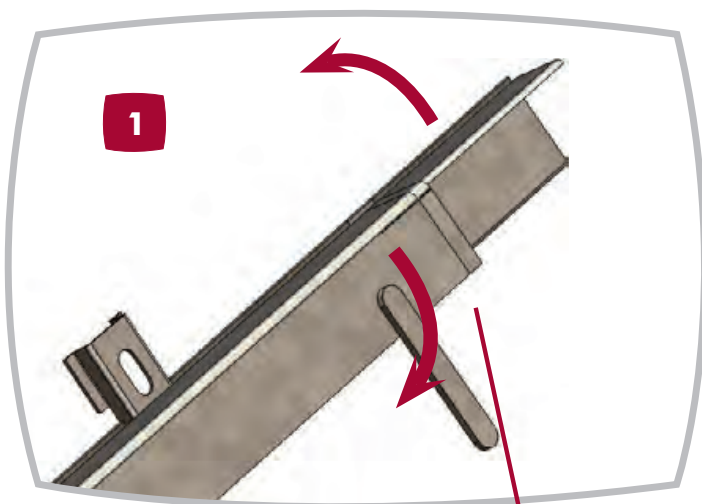

2

Position the fixing lugs: Hammer the second from top (2) and bottom fixing (4) lugs into place (figure 2) allowing a gap for the Lock bar lug (see step 1 page 17).

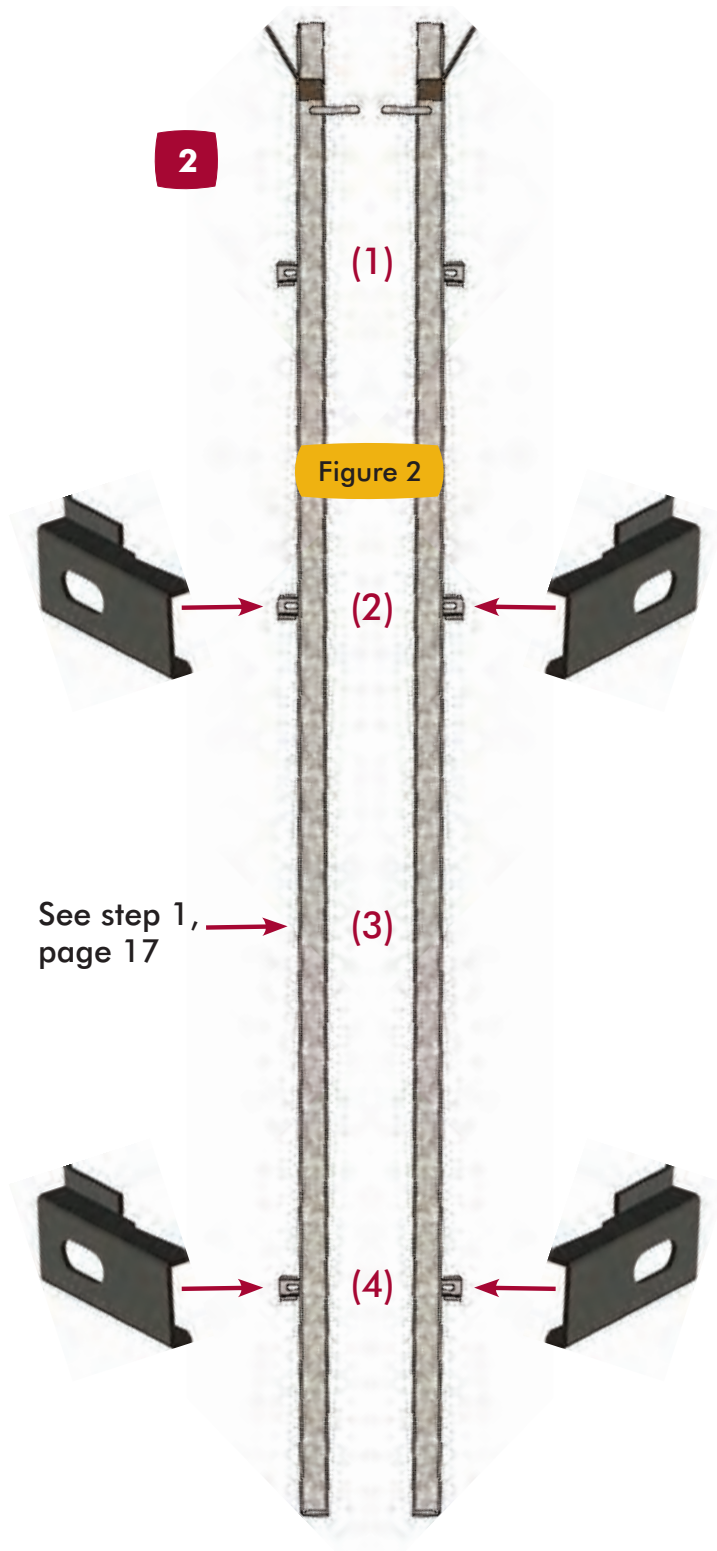

Position and mount the door

-  A minimum of two people must be available for fitting. However due to the weight and spring tension of larger doors, we insist that three people be available for installation **on doors over 10ft wide or 9ft high.**



-  Check axle length does not foul any obstructions. Cut down if necessary ensuring the axle is even and centred.
- 2** Lift the complete door curtain and axle onto the brackets ensuring that the roll is the correct way round with the bottom rail as shown below.

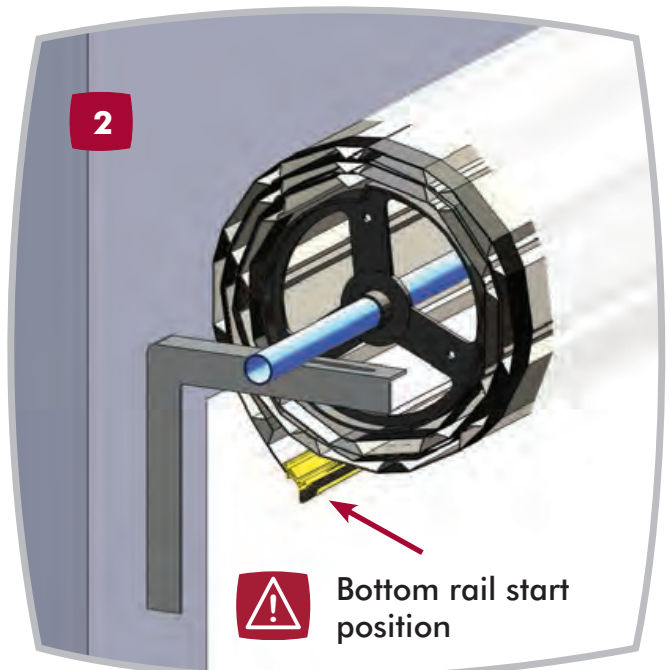
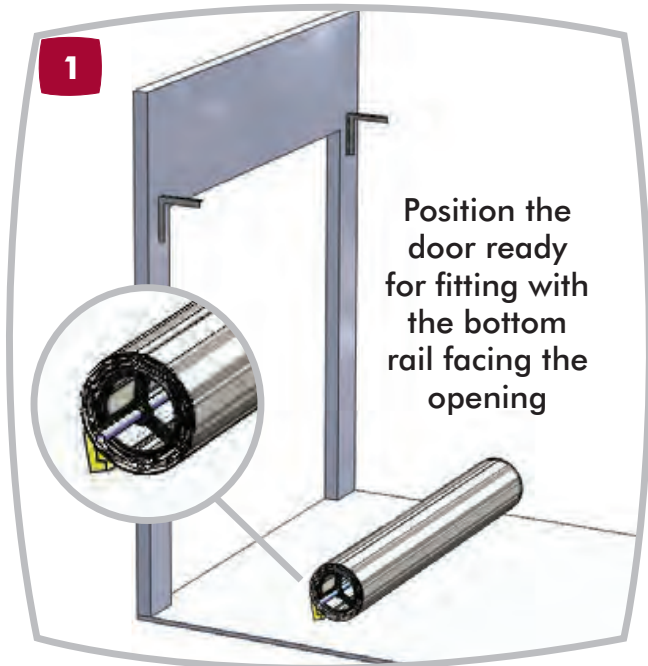

Whilst the door is on the floor, rotate the axle back and forwards through the roll to centre it



The Axle will protrude 11" (280mm) beyond the drum wheel at each side

- 3** Fit saddle and 'U' bolt, nut and washers loosely at each support bracket. See figure 1 for the location of Standard (main slot) and figure 2 for Mini doors (small and main slot)

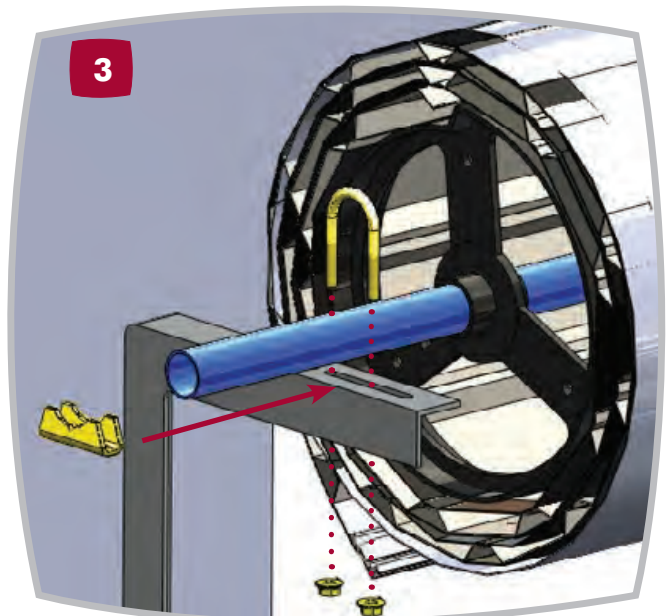

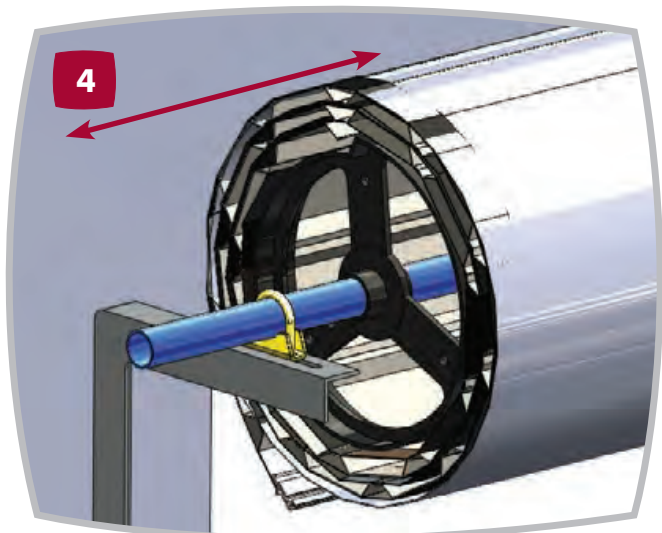
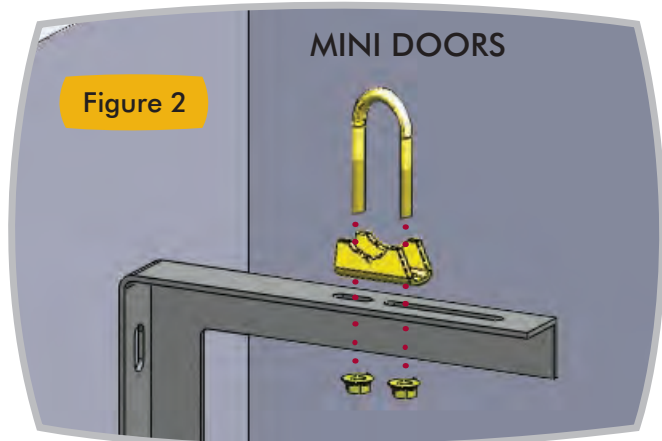
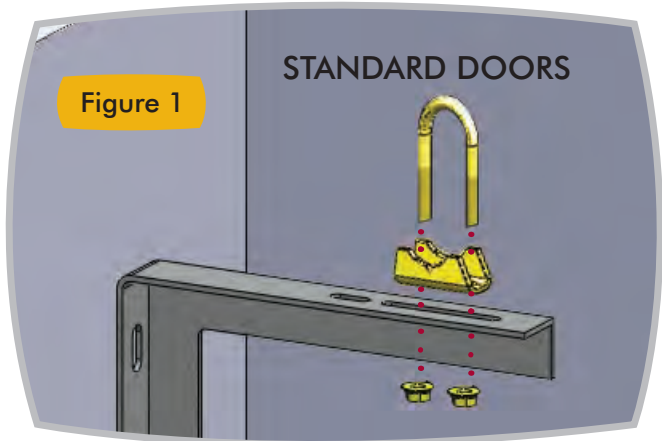

4 Centre the door roll in the opening by lifting the curtain and axle together and moving either way using the Curtain overlap marks on the wall as a guide. Make sure the axle protrudes evenly on both sides 11" (280mm) from the drum wheel

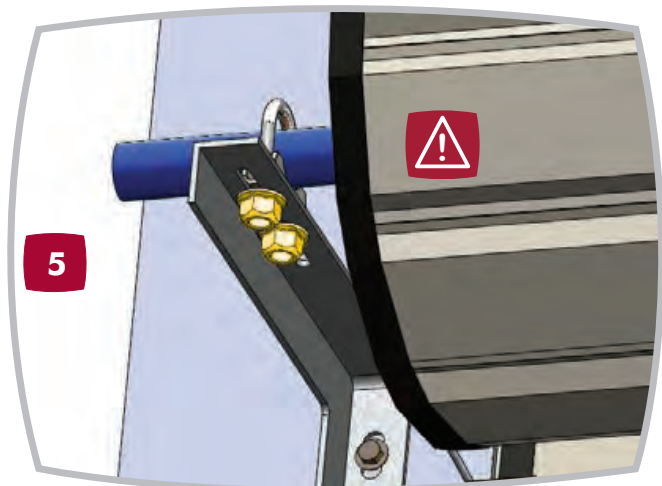
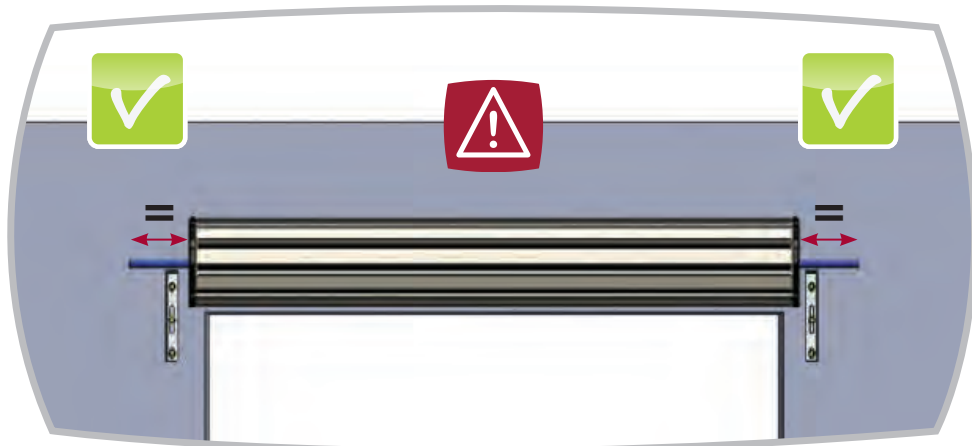

5 Tighten the 'U' bolts with the bottom rail at the start position as shown in point 2.

IF AUTOMATION IS REQUIRED – TIGHTEN ONE END ONLY. IF AUTOMATION IS TO BE FITTED SEE SEPARATE INSTRUCTIONS AT THIS POINT (SUPPLIED WITH YOUR AUTOMATION).

Tension the door & fix the guides

⚠ PRE-TENSION:- Do not cut the CARDBOARD bands that hold the door curtain in a roll. However, , if the door has a protective steel wrapping, cut the bands and remove this before you pre-tension.

⚠ WARNING DANGER! HIGH SPRING TENSION CAN CAUSE SEVERE INJURY OR DEATH. REPAIRS OR ADJUSTMENTS MUST BE MADE BY 2 PEOPLE.

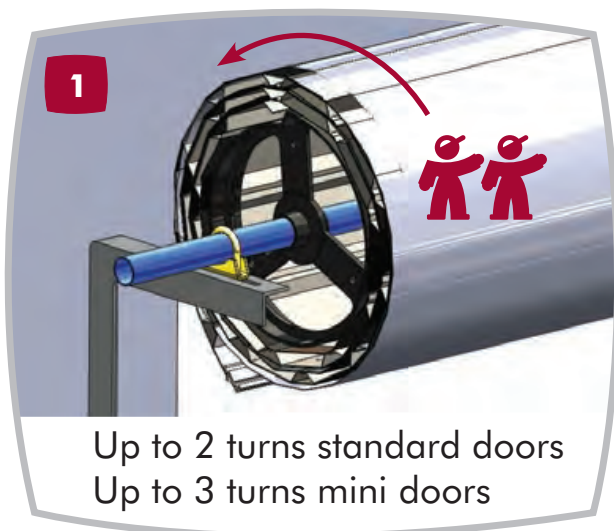

1 **IMPORTANT NOTE:** Pre-tension should now be applied to the springs by turning the curtain roll approx 2 turns forward for standard door and 3 turns for mini doors

The amount of pre-tension required may vary with individual doors and applications - See adjustments section on page 16 and 17.

2 Carefully cut the wrapping to expose a small portion of the bottom rail. Hold the door by the bottom rail before removing all wrapping. **DO NOT RELEASE THE BOTTOM RAIL.** The door will have a strong tendency to rise, WHICH IF UNCONTROLLED COULD CAUSE SERIOUS DAMAGE OR INJURY DUE TO SPRING TENSION. The door must be held until both guides are securely fixed in place.

⚠

PARTS REQUIRED

G 2x



FIXINGS REQUIRED

1

x8



2

x8

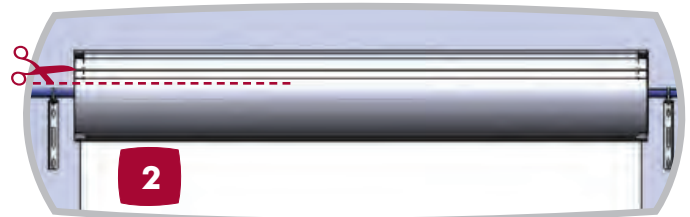

⚠ NOTE: Knife marks or cutting of the bottom seal or the nyloflex webbing voids the door warranty

⚠ A person must hold and control the door curtain at all times

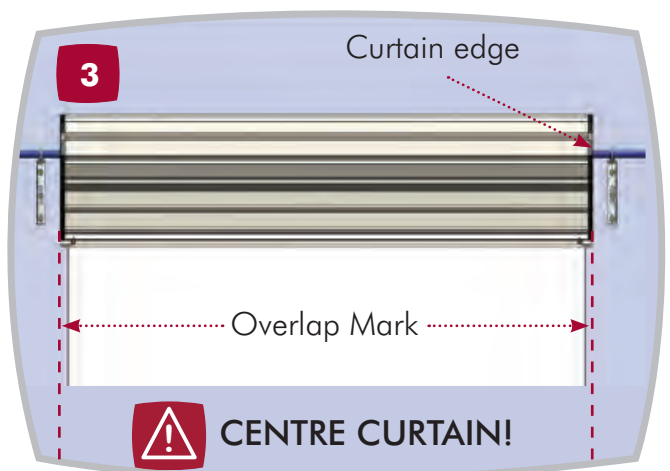

⚠ ENSURE THE DOOR CURTAIN IS CENTRED. IF ADJUSTMENT IS REQUIRED, CENTRE THE DOOR ROLL BY LIFTING THE CURTAIN AND AXLE TOGETHER

- 4** Slide each guide onto the door curtain allowing approx 3-5mm clearance between edges of curtain and inside edge of guide to ensure door travels smoothly.

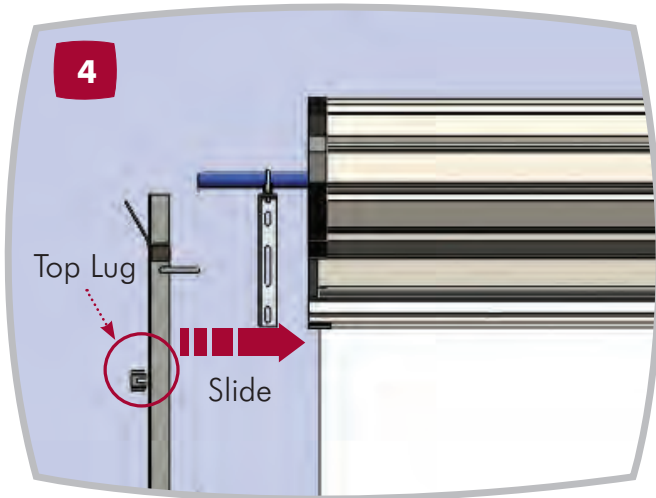

- 5** Drill wall and fix the top lug of each guide with a 10mm x 65mm sleeve anchor or coach screw.

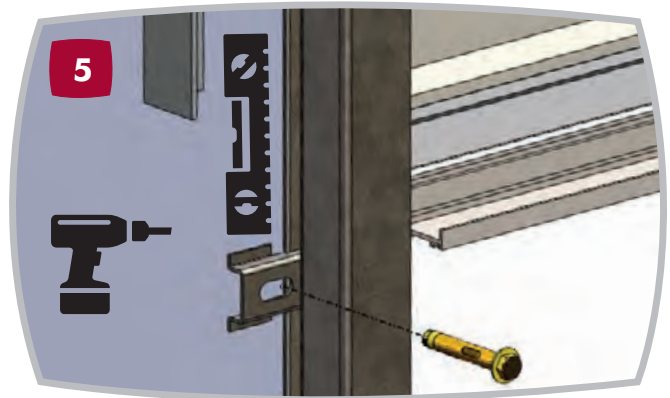

- ⚠** CHECK GUIDES ARE VERTICAL AND PARALLEL!

Fix the remaining lugs.

Fitting the stop bar catchers

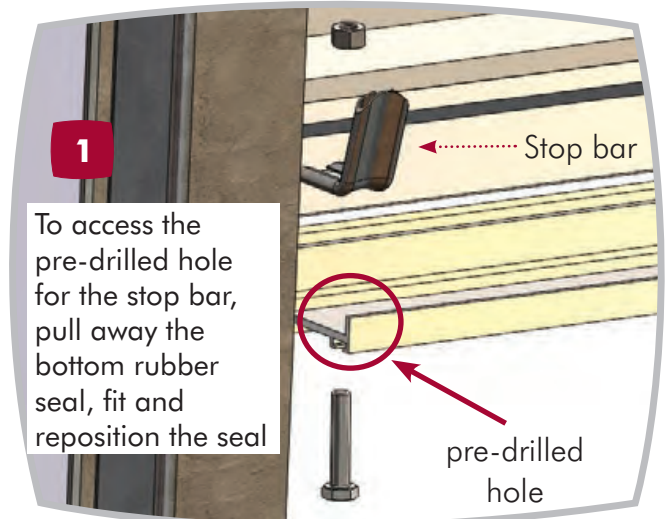
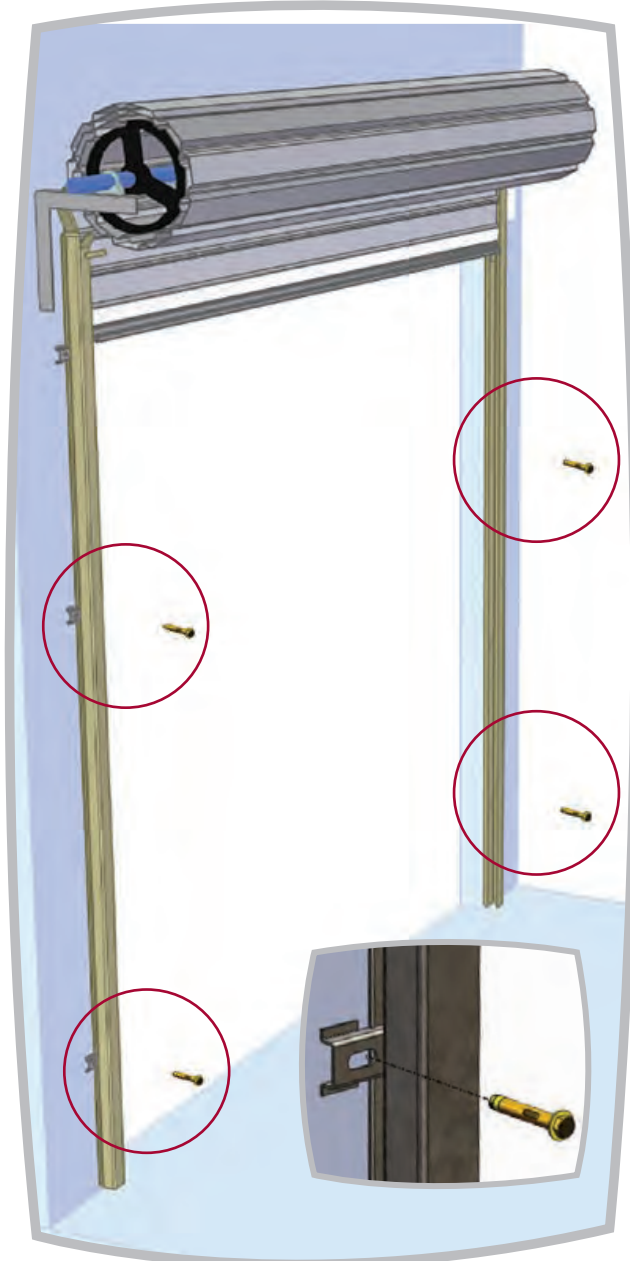

1

To access the pre-drilled hole for the stop bar, pull away the bottom rubber seal, fit and reposition the seal

pre-drilled hole



THE BOTTOM EDGE OF THE GUIDE STOP BARS MUST NOT BE CLOSER TO THE HORIZONTAL PART OF THE SUPPORT BRACKETS THAN DISTANCE 'F'.
 F=220MM STANDARD DOORS
 F=140MM MINI DOORS
 IF THIS IS NOT OBSERVED THE DOOR WILL BE DIFFICULT TO CLOSE



IF THE BRACKETS WERE FIXED 10MM LOWER TO ALLOW FOR FITTING ON THE LIMIT OF HEADROOM CLEARANCE, THESE CAN NOW BE TAPPED UP TO ACHIEVE THE FINAL POSITION. BRACKET LEVEL MUST BE CHECKED ON COMPLETION OF TAPPING UP.

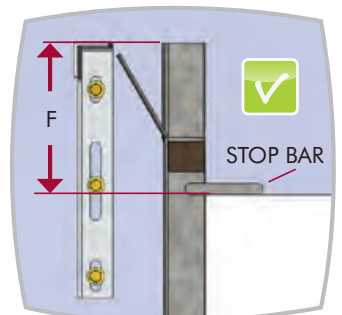

Check door settings

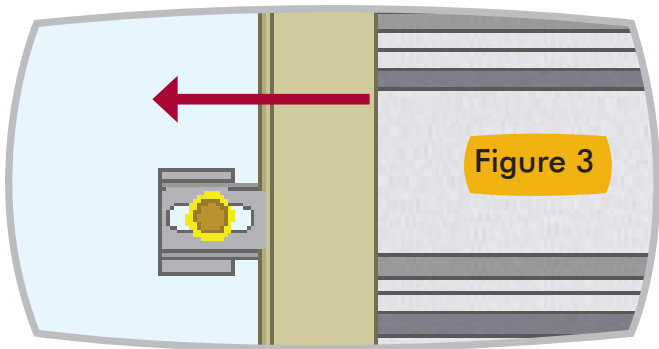

GUIDES: Now that you have both guides firmly fixed, pull the curtain down slowly. Continue to pull the curtain down to the floor ensuring that it runs freely. If it does not, reposition guides for clearance 3-5mm as necessary (fixing lugs are slotted for adjustment - figure 3).

CONING: Check that the door rolls up evenly and squarely with the ends of the roll, if it rolls out unevenly (cones out at one end) repeat FINAL adjustment section on page 16.

DOOR TENSION: The door is now installed. Lower the door curtain to the half open position to check that the spring tension is in balance. From this position the door curtain does not rise or lower of its own accord when released.

The door should be slightly over tensioned during this running in period. i.e. when put to the ground it should want to rise 25mm - 40mm unless locked down.

PARTS REQUIRED

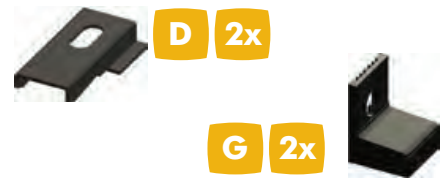

IF THE DOOR IS NOT SET PROPERLY COMPLETE THE FINAL ADJUSTMENT SECTION (P18) BEFORE CUTTING THE LOCK BAR HOLES.

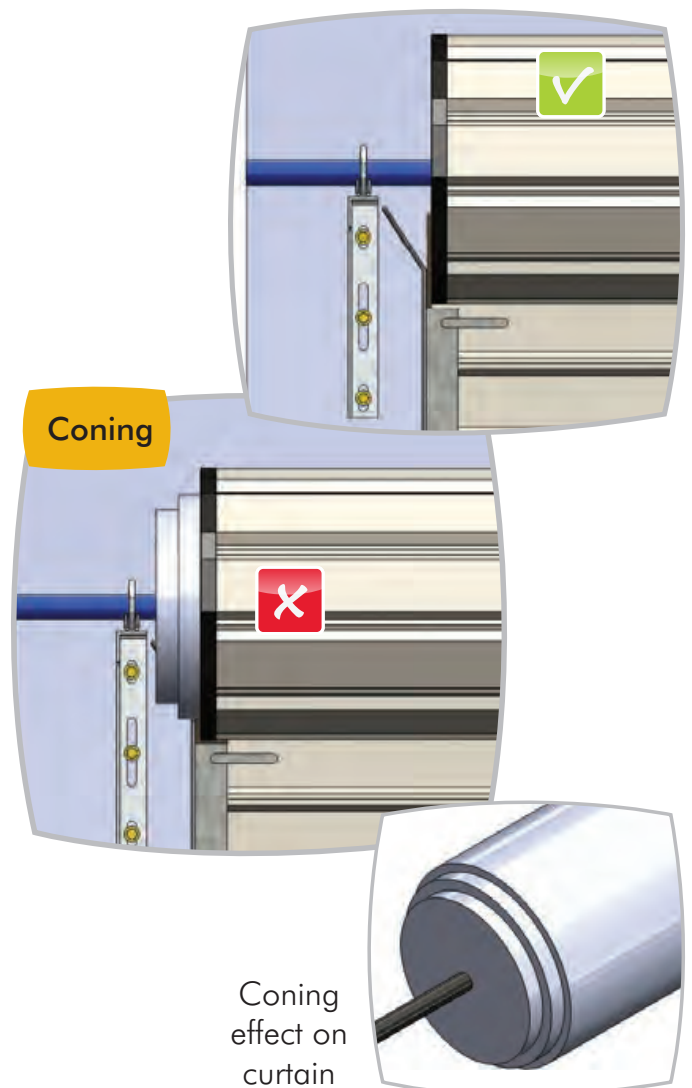

Cut lock bar holes & fit finger protection

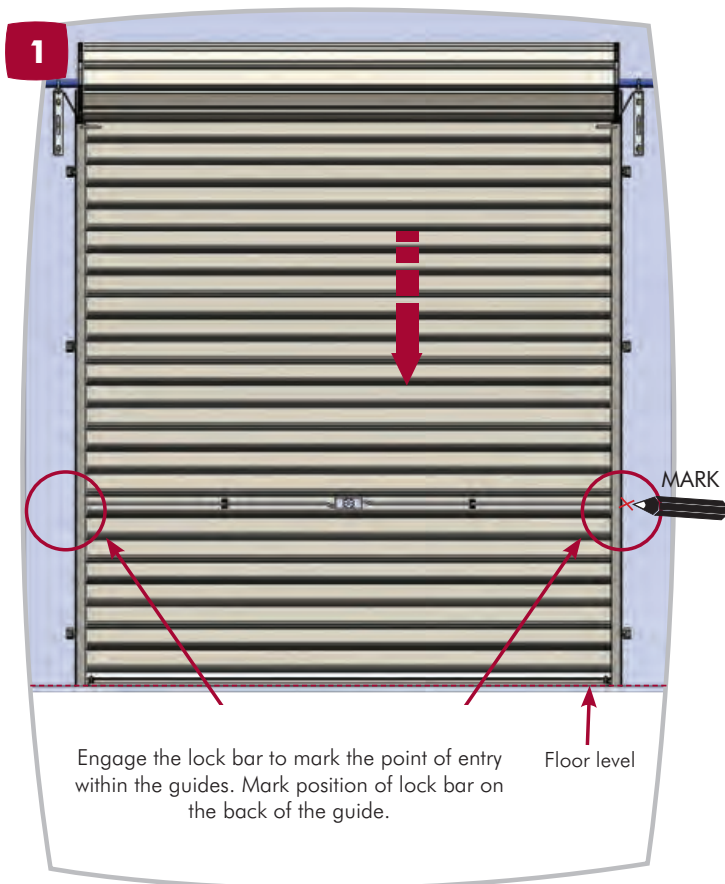

⚠ TO MARK THE GUIDES FOR THE LOCK BAR HOLES, THE DOOR MUST BE FULLY CLOSED

3 Position the final guide lug aligned with the lock bar slots, fit the finger protection lock bar covers and fix in place.

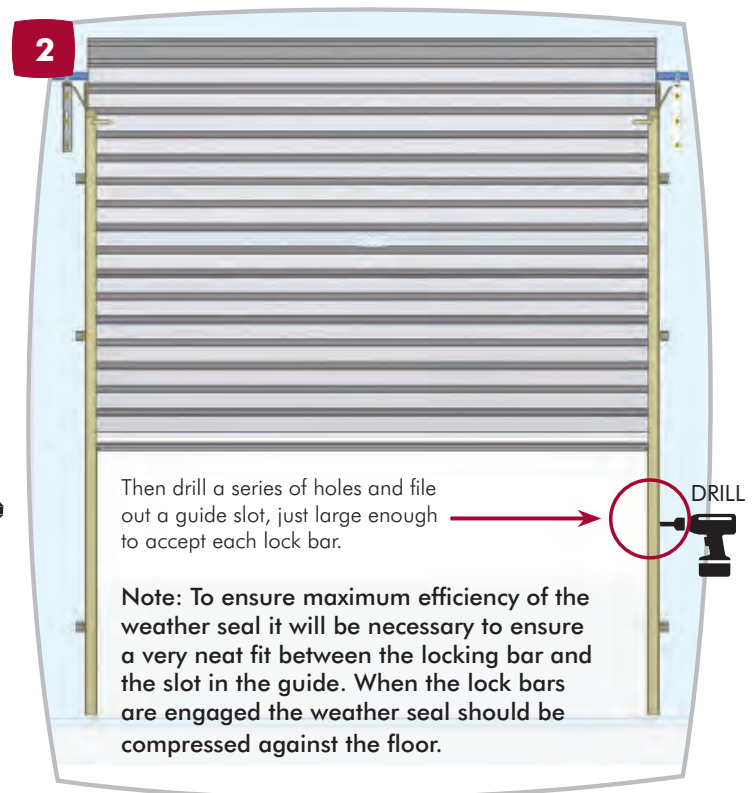
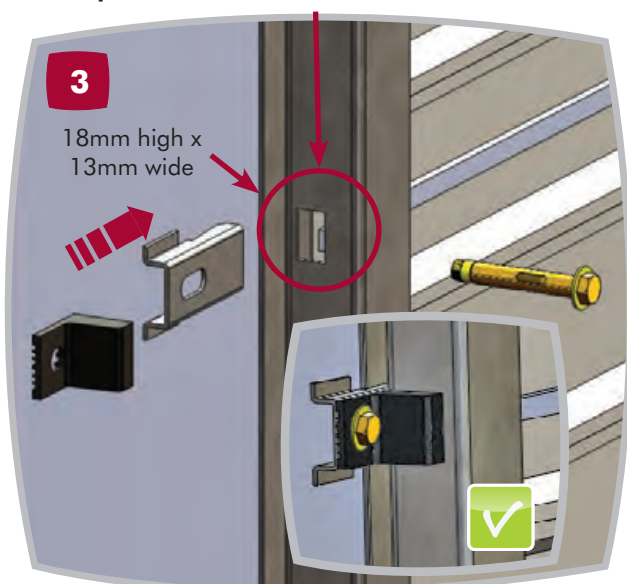

⚠ SECURITY NOTE FOR AUTOMATIC DOORS

To stop attempts to prise the bottom of the door up, the curtain can be secured to the drum wheel.

⚠ WARNING: DO NOT RAISE DOOR WITH THE KEY IN LOCK!

Fully close the door, mark the corrugation just before the curtain leaves the top roll. Open the door partially, approximately 400mm, so you are able to see the mark.



Drill through the curtain and drum wheel rim and fix with a self tapping screw.

Final adjustments & troubleshooting

DIFFICULT TO OPERATE IN EITHER DIRECTION

- Check that the curtain is not jamming in the guides.
- Check running clearance in the guides (3-5mm per side).

DIFFICULT TO CLOSE

Decrease the spring tension (See spring tension adjustments page 19).

GUIDE/AXLE RELATIONSHIP (SEE FIGURE 3)

If the door is very difficult to close during the last 600mm of travel, check that the guides are fitted in the correct relationship to the brackets and that the axle is the correct distance from the wall. (see step 3, page 10, 11). One or both will be incorrect, thereby increasing lead angle into the mouth of the guides, making the door difficult to close.

CONING (SEE FIGURE 4)

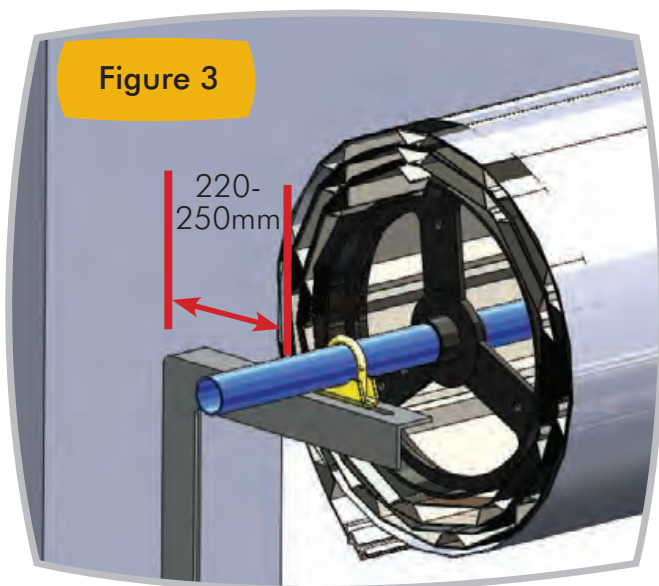

If the curtain rolls up unevenly (cones out at one end) and the bottom rail appears out of parallel with the door roll and guides, check for the following:

- Brackets not level.
- The axle is not the same distance back from the wall at each side.
- Axle not correctly centralised in roll.

If the brackets are level and the axle distance from the wall is equal at both sides, remove the coning by moving the axle through the roll in the opposite direction to the coning.

This operation should be done by minimum of two people and ensure the door is fully rolled up to minimise spring tension before starting.

CONING ADJUSTMENTS

Follow the steps in final spring tension adjustments, (see next section) up to (e) where it states "to increase tension". Do not rotate the axle unless spring tension is to be changed. While still retaining a firm hold on the axle to prevent axle rotation using a pipe wrench, the axle should be lightly tapped in the direction of the coning (See figure 4). Move no more than 20mm at a time. Then follow the steps and secure axle. After adjustment the door needs to be opened and closed 2-3 times to settle the new alignment. You may need to repeat this step a number of times.

If coning persists, fitting of an anti coning collar/exhaust clamp (1 3/8"/35mm) may be necessary. Note the side to which the door is coned and, with the door closed, fit an anti coning collar onto the axle tight against the boss of the drum wheel to prevent movement to the left or right as the door opens or closes. (Figure 5)

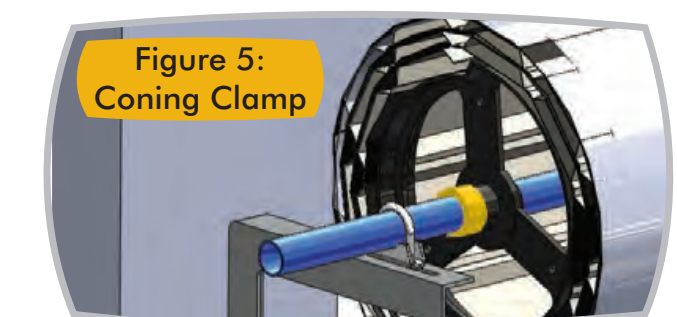
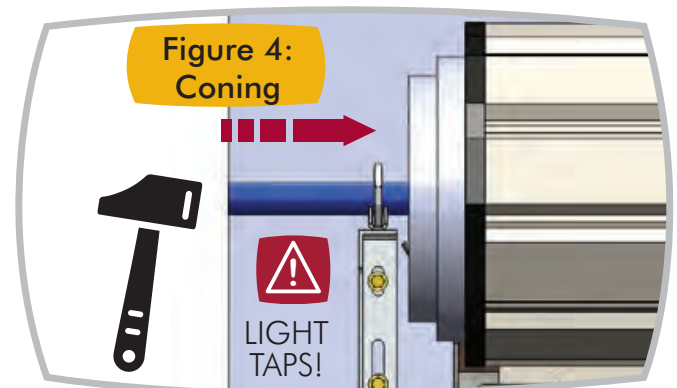

FINAL SPRING TENSION ADJUSTMENTS (SEE FIGURE 6)

⚠ AS A PRECAUTION, ATTACH A PIPE WRENCH AT THE OPPOSITE END TO BE WORKED ON AND ENSURE IT IS HELD TIGHTLY BY ANOTHER PERSON.

(a) One 'U' bolt clamp should be selected to loosen first and the other side should remain fully tightened. The remaining tight 'U' bolt clamp will retain the existing tension when the door is fully open (rolled up). However, as a precaution a pipe wrench must be also be attached to the axle at the opposite side to be worked on and held tightly by one of the installers.

⚠ THIS OPERATION SHOULD NOT BE ATTEMPTED WITH THE DOOR IN THE CLOSED POSITION AS THE TENSION IS VERY MUCH GREATER AND COULD LEAD TO DAMAGE OR SERIOUS INJURY.

(b) Loosen but do not fully remove the selected 'U' bolt clamp.

(c) One person should then grip the axle on that side firmly with an 18" pipe wrench.

(d) The other person should then move to the other end of the door roll and with an 18" pipe wrench, grip the axle firmly. Loosen but do not fully remove the other 'U' bolt clamp until the axle is free.

(e) To increase tension pull down on the pipe wrench and to decrease tension allow the pipe wrench to move up (see figure 6).

(f) Fully tighten adjacent 'U' bolt clamp while holding tension with a pipe wrench. Do not release pipe wrench until 'U' bolts are tight. (Ensure that it never slips as this would cause loss of tension and possible injury or damage to door).

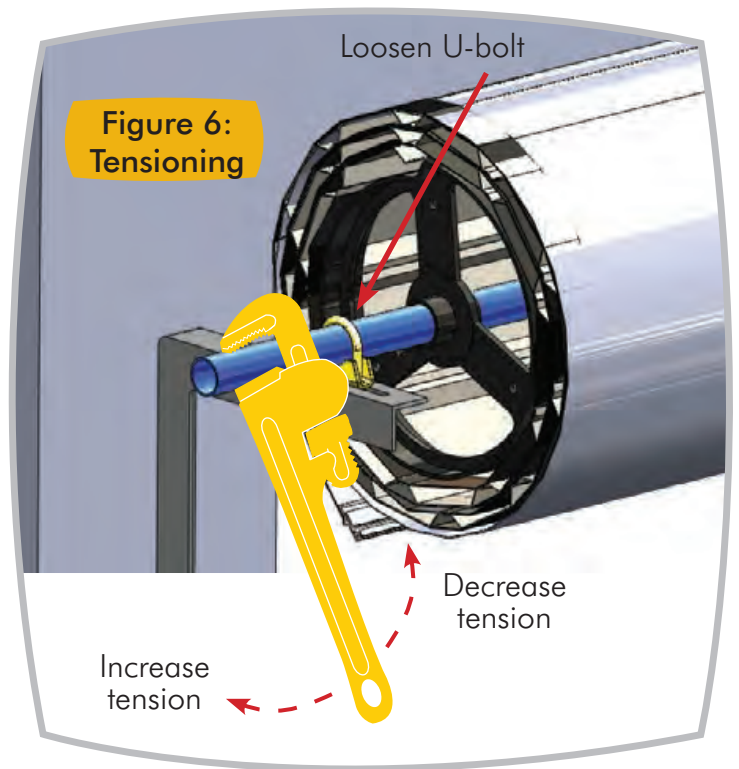

MAINTENANCE

The following suggestions will keep the door working efficiently.

1. Do not grease or oil the guides.
2. Periodically clean the inside of the guides with white methylated spirits or similar and spray with silicone spray or car/furniture polish.
3. It may be necessary to lubricate the locking mechanism via the key hole using graphite dust lubricant if operation becomes difficult.
4. Your door should be washed with a quality car shampoo at least every 2 months to prevent the build up of dirt, salt and other corrosive substances. If your door is installed within 2 miles of the sea, your door should be cleaned in this way **at least monthly**.

⚠ WARNING! DANGER! HIGH SPRING TENSION CAN CAUSE SEVERE INJURY OR DEATH. REPAIRS OR ADJUSTMENTS MUST BE MADE BY TWO PEOPLE USING PROPER TOOLS AND INSTRUCTIONS.



**YOUR SAFETY
FIRST!**

Read this booklet
carefully before
installing your door



**HEAVY -
LIFT WITH
CAUTION!**

