



GLIDEROL GARAGE DOORS

Installation Instructions

MINI ROLL DOORS up to 3759mm wide and 2100mm high

PARTS LIST

MINI ROLL DOORS

- 2 25mm Side Tracks
- 2 Mild Steel Mounting Brackets
- 2 U Bolts with Nuts
- 2 Pressed Steel Saddles
- 16 Washers
- 8 Fixing Lugs
- 8 M10 x 70mm Coach Screws
- 4 M12 x 70mm Coach Screws
- 1 Handle with Fixings

RECOMMENDED TOOLS

- | | |
|--------------|-------------------|
| Tape Measure | 10mm Masonry Bit |
| Spirit Level | Bit |
| 13mm Socket | 12mm Masonry Bit |
| 15mm Socket | Bit |
| Hacksaw | Orbital Drill Bit |
| Claw Hammer | Stilsons |
| File | Stanley Knife |
| | Power Drill |

N.B. Door Installer should determine on site the most appropriate type of fastener and wall plug for the material which the brackets are to be attached to.

IMPORTANT:

For automatic door installations, these instructions must be read in conjunction with separate Glidermatic Roll-A-Matic instructions.

The minimum amount of side room required from the edge of the curtain to the inside of the bracket needs to be 135mm when fitting the RW-1

1 PREPARATION

DO NOT REMOVE THE PACKAGING UNTIL TENSION HAS BEEN APPLIED TO THE DOOR (see Stage 3, page 2).

Before commencing, measure both the opening and the door curtain and mark the overlap on the wall, ensuring a minimum clearance of 10mm is allowed at each side to facilitate the fixing of brackets and side tracks. This door will be positioned behind the opening, therefore overlap the opening on each side by a minimum of 25mm. For manual doors a minimum of 50mm is required from the edge of the curtain to the side wall for Mini Roll Doors.

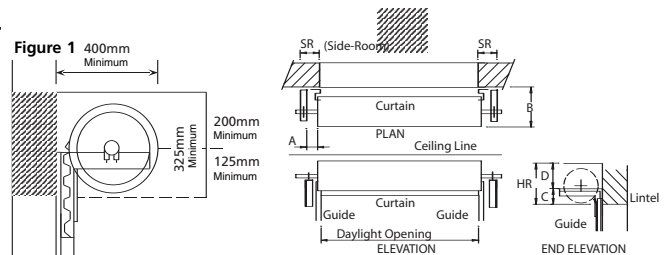

DIMENSION PANEL (minimum sizes) mm						
Mini Roll (Hand Operated)	Side Room	Head Room	A	B	C	D
2100 HIGH	90	325	25-100	400	125	200
For RW-1	160					

2 AFFIXING MOUNTING BRACKETS

The headroom between the underside of the ceiling/roof truss and the top of the opening/underside of the lintel should be a minimum of 325mm for Mini Roll doors. See headroom clearance box (Fig. 1). If the recommended headroom is not available the door may still be installed maintaining the required headroom, however some loss of opening height will occur and the roll of the door will be visible. This can be disguised by a fascia. Any excess curtain will remain on the roll.

The top of the slotted bearing surface of the mounting brackets (see Fig. 4, page 2) should be 125mm from the top of the opening/underside of the lintel and a minimum of 200mm from the underside of the ceiling/roof truss. If the recommended headroom is not available the 200mm measurement must be maintained.

It is important that the outside face (smooth side) of the angle bracket faces the sidewall of the garage. Drill and plug then firmly secure one of the mounting brackets with 50mm coach screws. N.B. Coach screws should not be used without the appropriate wall plug for the material you are fixing to.

The clearance on either side between the door curtain and the mounting brackets is a minimum of 10mm, or a maximum of 75mm.

The minimum amount of side room required from the edge of the curtain to the inside of the bracket needs to be 135mm when fitting the RW-1

It is vital that the second mounting bracket is positioned with the use of a laser level/spirit level to ensure the THE BRACKETS ARE EXACTLY LEVEL WITH ONE ANOTHER.

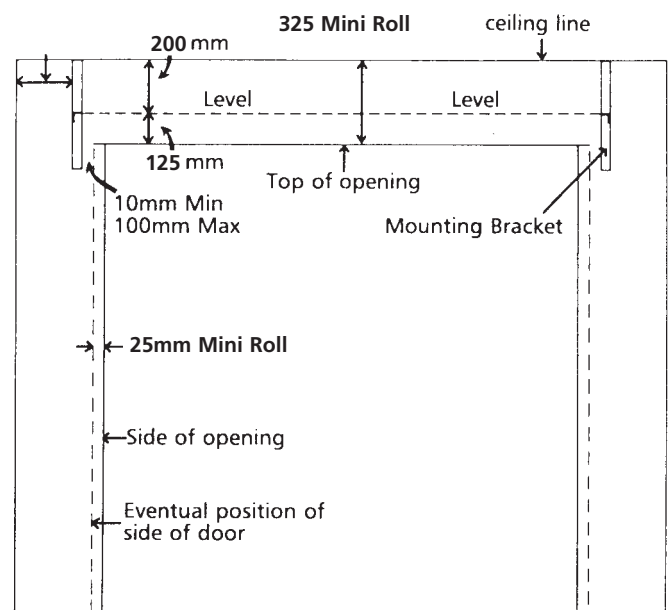

3 POSITIONING THE DOOR

Before lifting ensure that the door is centralised on the axle, so that an equal length of axle is exposed at either end. Measure from the overlap mark on the wall (take in stage 1) to side obstruction (e.g. wall) (see fig. 2). If sufficient side clearance for the axle is not available the axle may be shortened, ensuring that 50mm remains on either end. IT IS IMPORTANT THAT THE AXLE IS NOT CUT TOO SHORT. Ensure that the door is placed the correct way round on the bracket and that the bottom rail is in the correct position. Figure 4 illustrates the relative position of the bottom rail from a side view perspective (side packaging may be carefully cut away at this stage only to reveal the end of the roll).

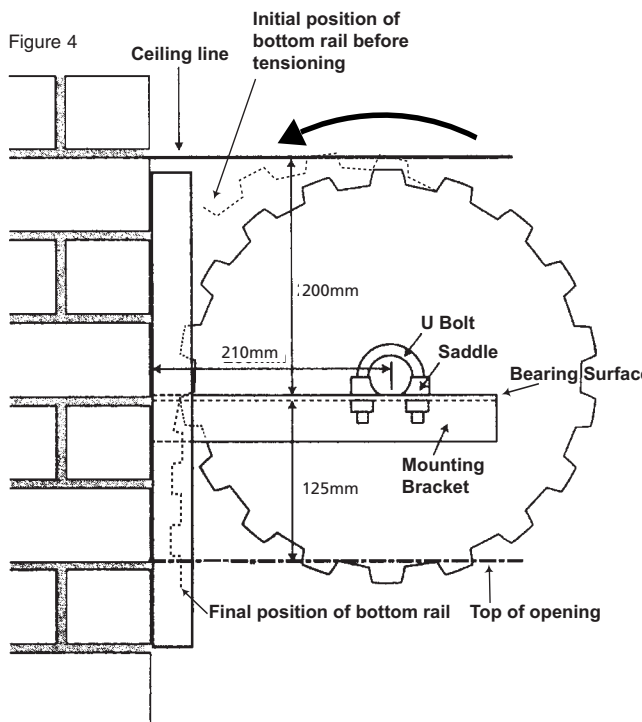
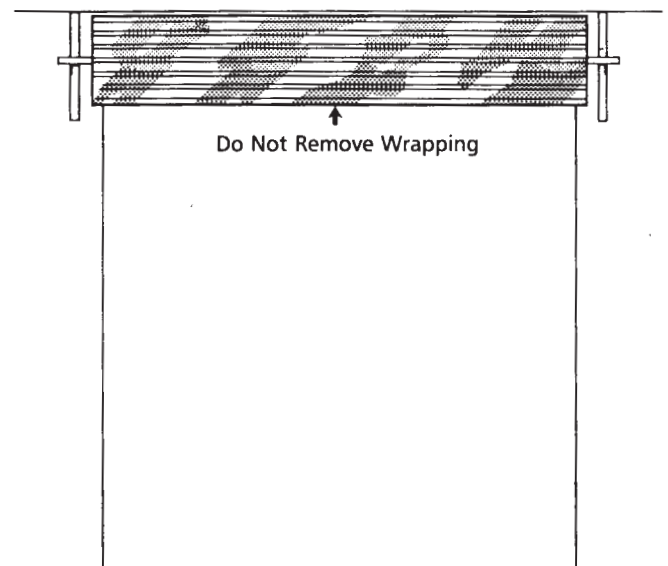

Figure 3



Secure the axle to the mounting brackets with the U bolts and pressed saddles (see Fig 4 for position). LOCK THE U BOLTS TIGHTLY ensuring washers are placed under the nuts.

Spring tension will be lost if the axle is not firmly clamped.

Tension should now be applied to the spring by rotating the door approximately half a turn to begin with in a forward direction as shown on Figure 4. The amount of tension required to give the best operation may vary with individual doors and final adjustments should be made upon completion of the installation.

4 UNROLLING THE DOOR

Holding the door in the tensioned position carefully cut the wrapping. **It is important that the door is held firmly at this stage to prevent loss of tension.** Keeping hold of the door pull the door carefully open and remove all wrapping.

N.B. The door may have a strong tendency to rise, which, if uncontrolled, can cause damage/injury.

Still holding the door, allow the door to roll up evenly ensuring it is straight on the drum. Place a piece of soft timber, approximately 450mm long as a choc in between the bottom rail and the drum, as shown in Figure 5, taking care not to damage the door.

Figure 5

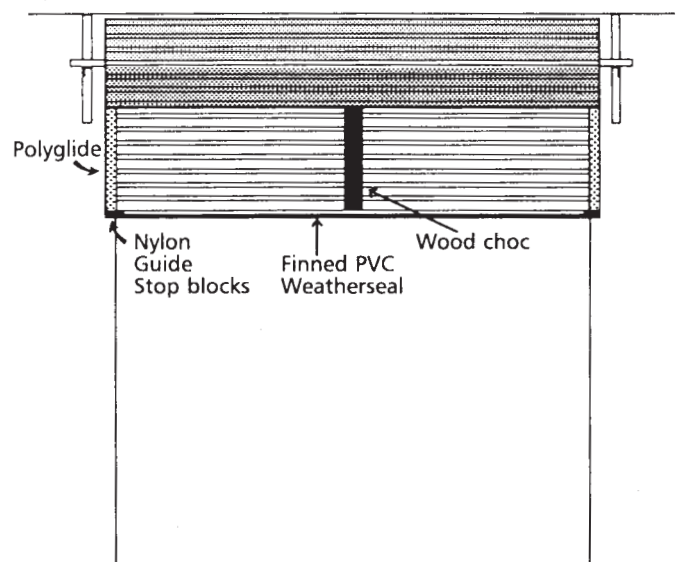

5 FIXING THE SIDE TRACKS

Clean the side tracks with a spirit cleaner

Using a hammer flatten the top 20mm of the back edge of the top of the track. Using the claw end of the hammer form a curl on the front edge of the track (Fig 6b). Insert and tap fixing lugs fully into sides of one track at regular intervals. The lowermost lug should be positioned approximately 200mm from the floor (Fig 6a). The bottom of the side tracks must be flush with the floor. If the floor is slightly out of level, always work from the higher floor side first.

Ensure that the top of the track is 25mm above the top of the bearing surface of the bracket. Slide the track on to the door curtain allowing 4mm clearance from the edge of the door to the edge of the track, ensuring that the door remains straight. Hold the track in position against the wall and mark, drill, plug and fix the top lug with a 70mm coach screw. NOW USE A SPIRIT LEVEL TO ENSURE THAT THE SIDE TRACK IS VERTICAL and fix the track in position via the remaining lugs ensuring that the bottom lug is approximately 200mm from the floor.

Repeat this process for the second track.

Tracks may require cutting at this stage. **N.B. excess should be cut from the BOTTOM of the track.**

With the door positioned within the tracks carefully remove the wood choc (if used). Ensure that the door curtain rolls up evenly and centred within the opening.

PLEASE NOTE: All dimensions given are for guideline purposes only and final adjustments may have to be made depending on the garage specifications.

Figure 6a

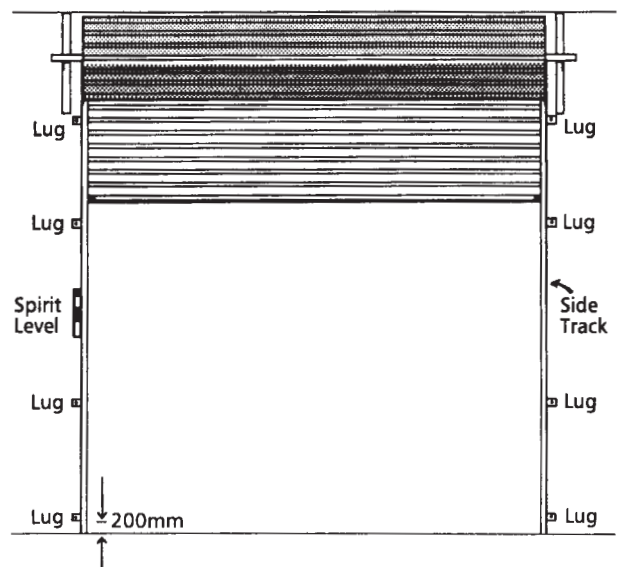
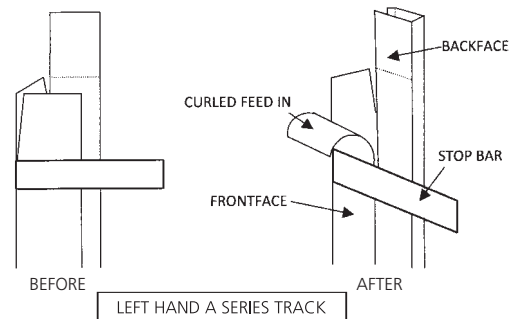

Figure 6b



6 FINAL ADJUSTMENTS

At this stage the door should roll up and down then the tracks. Tracks may be adjusted slightly if necessary.

If the door feels heavy or light when rolling up and down then the tension should be adjusted. The balance of tension on the doors should ensure that the door neither rises nor falls of its own accord or is difficult to lift or pull down (see Fig 7 for instruction on how to increase/decrease tension).

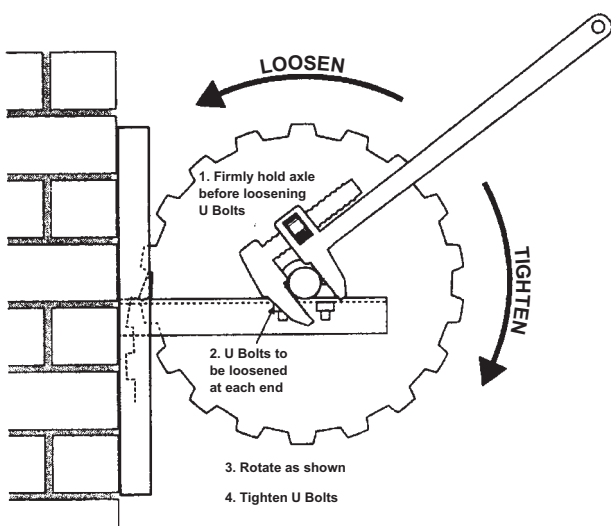

7 FITTING LOCKING BAR

With the door closed and firmly seated on the floor, mark the point of contact of the centre line of the locking bar on each track. Drill a hole in the track using an orbital drill bit to accommodate the locking bar. File edges of hole as required. A neat fit will minimise the vibration and maintain efficiency of the weaterseal.

Affix the lifting handle in the centre of the aluminium bottom rail (do not attach to door curtain). Raise the door to track stop for correct positioning on aluminium bottom rail. Marl, drill and fix with gutter bolts.

Additional stops should be fitted at this stage to AA series doors on the aluminium bottom rail in line with track stop.

GLIDEROL DOES NOT REQUIRE LUBRICATION

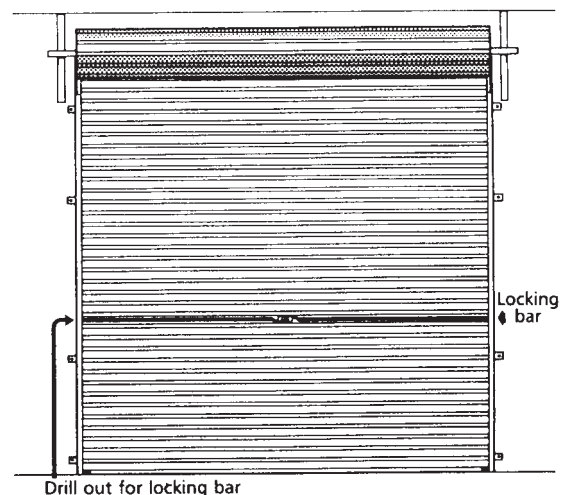

INSTALLATION FAULTS AND REMEDIES

FAULTS

- Door hard to operate in one direction
- Door hard to open in both directions
- Door makes bumping sound during operation

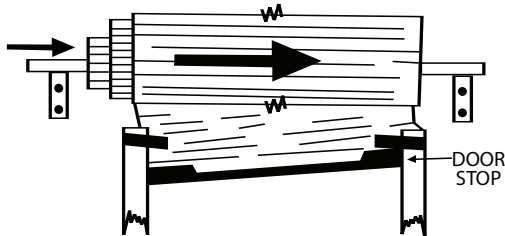

Door rolls up unevenly/bottom rail of door rolls up out of parallel with roll of door/edge of roll is not flush, i.e. door is rolling up in a spiral or cone shape (see diagram above).

WARRANTY: Electrical Components 2 years • Mechanical components 6 years
 Door Finish 10 years (conditions apply)
 Full warranty details available at www.gliderol.co.uk

REMEDIES

Adjustment spring tension (stage 6)

Check track clearances to ensure door is not jamming (stage 6)

Check tracks are not too long (stage 5). Ensure door is positioned on brackets the same distance from the lintel/wall at either end of the door. Door must be in open position and adjustment may only be made to one side at a time. Ensure opposite U-bolt is secure/tight before proceeding, tension will be lost if this procedure is not adhered to. Loosen U-Bolt and push that side of the door towards the opening as far as possible without scraping the lintel. Tighten U-Bolt and repeat operation with other side, ensuring axle is still parallel with opening (top lug on side track may be packed out).

Check that the mounting brackets are level with one another. Axle may not be in centralised position (see stage 3 and adjust accordingly).

Important in the Operation of Gliderol Garage Doors

- 1** In the interest of your safety and others, this door must only be operated by users familiar with its operation.
- 2** When operating the door do not place fingers near guides or other moving parts at any time.
- 3** The person operating the door must have it in sight at all times during its operation.
- 4** Do not allow children to play with garage door and any associated parts, including electrical controls
- 5** Do not attach any objects to, or make any modifications to the door as this may cause damage and/or physical injury.
- 6** Operate the door only when properly adjusted and free from obstruction.
- 7** Should the door become difficult to operate or completely inoperable, call a qualified technician. Repairs and adjustments should only be undertaken by experienced door service personnel.
- 8** As polyglide is self lubricated it is important **NOT to lubricate guides with any oil or grease.** It is advisable to occasionally clean guides with spirit cleaner to remove and dust particles