



SeceuroDoor
Industrial Doors

Samson Industrial Roller Door Range 2017



EMAIL: ENQUIRIES@SAMSONDOORS.CO.UK
TELEPHONE: (01933) 274276
MON - FRI - 8.30AM - 5.30PM



Welcome the Samson Industrial Roller Shutter Door Range

Roller shutter doors for the purpose of access into any building from just one operation a day up to constant use 24 hours a day. Made to measure sizes as standard with multi fix options and multi option electric drive and control options. Single skin basic steel construction and double skinned insulated curtain options in a range of standard colours with options on any RAL or BS colour.

- * All doors are fully compliant with latest UK safety requirements
- * All doors are made to order for the perfect installation and specification
- * Easy fit options with flexible installation components which can be adjusted on site
- * Highest quality components in the door construction, no plastic or inferior small components
- * Electric motor drive options with latest control panel design and easy programming

"Don't buy cheap and end up buying twice, get it right the first time with a Samson Door"



Reasons to Choose Samson

✓ A name you can trust

When buying a product from Samson you can be reassured by the values behind the name. Samson manufactures are CE marked and some also hold an ISO9001 and ISO14001 Certified Company.

✓ Expert advice

With a full-time technical team, field support and a helpline on hand you can be confident in choosing a product with first class backup and service.

✓ A solution for everyone

With so much choice from Samson, our vast range of products can accommodate most industrial door requirements, whether you need insulation, vision, or are looking for a solution for a specific budget.

✓ Engineered to perfection

In partnership with some of Europe's biggest manufacturers, whose continuous development and specialist engineering, products offer unrivalled quality and the most advanced specifications. High emphasis is placed on ease of fitting and flexibility on site.



The Simple All Rounder

A galvanised steel single skin door curtain construction in manual or electric operation options. This is the roller door for unheated buildings with multiple options on drive methods.

Max. Width 7000mm (manual operation 5000mm)

Max. Height 7000mm (manual operation 5000mm)

Ideal for: Unheated buildings, warehouses, farm buildings, storage facilities.

Wind Class Rating: Class 3 (with 65mm + guides)

Common Options:

- ✓ Security Rated version LPCB level 2
- ✓ Perforated or Punched slats for vision and ventilation
- ✓ 'Continental' version with tube motor operation for low use and where space may be limited
- ✓ Plastisol coated slats to match cladding colours
- ✓ Wicket pass door

VISION SLAT (PUNCHED)*

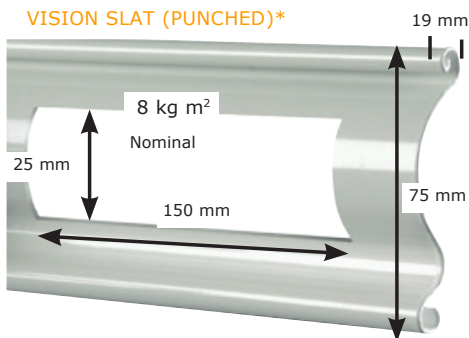

THIS PRODUCT CAN BE
POWDER COATED

Please note: that this product will be powder coated after it has been assembled.



THIS PRODUCT CAN BE
PLASTISOL COATED

Please note: this finish applies to the external face of the curtain slat only.

SLAT (SOLID)



SLAT (PERFORATED)

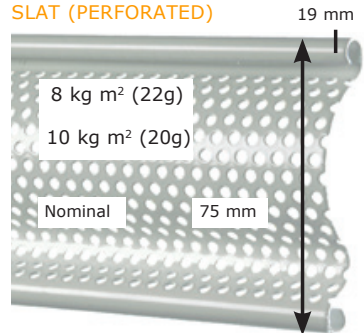



The Cost Effective Solution for Smaller Openings

A galvanised steel double skinned insulated door curtain construction in manual or electric options. All the flexibility of the 75 but with the insulated slat.

Max. Width 6000mm

Max. Height 3400mm

Maximum size is 20 m² as an industrial style specification with a maximum 6000mm width

Ideal for: Heated buildings, workshops, garage workshops, smaller commercial buildings.

Wind Class Rating: TBC

Heat Transmission for slat profile: 4.01 W/(m² K)

Common Options:

- ✓ Powdercoated RAL or BS colours
- ✓ Remote control operation
- ✓ Roller curtain hood cover for maximum protection against ingress of dust and draughts.

SLAT (INSULATED)



THIS PRODUCT CAN BE
POWDER COATED

Please note: that this product will be powder coated after it has been assembled.





The Insulated All Rounder for Larger Openings

A galvanised steel 95mm deep double skinned insulated curtain construction with a unique and attractive external slat design. This is a great insulated roller door with standard colour options.

Max. Width 7000mm

Max. Height 7000mm

Ideal for: Heated buildings, larger factory doors, workshops.

Wind Class Rating: Class 3

Heat Transmission for slat profile: 3.9 W/(m² K)

Acoustic reduction rating: 27 dB

Common Options:

RAL or BS colour options, can be different colour inside to outside Clear perspex vision slat sections at 100mm x 55mm each

Higher speed, variable speed motor drive systems

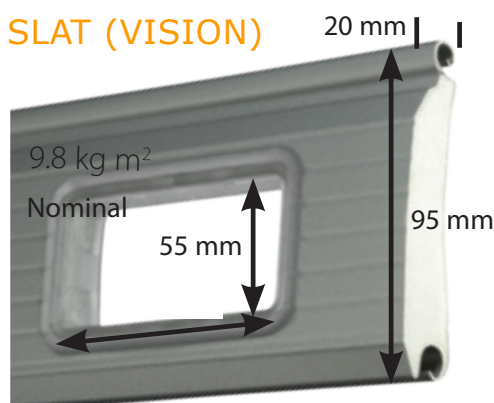
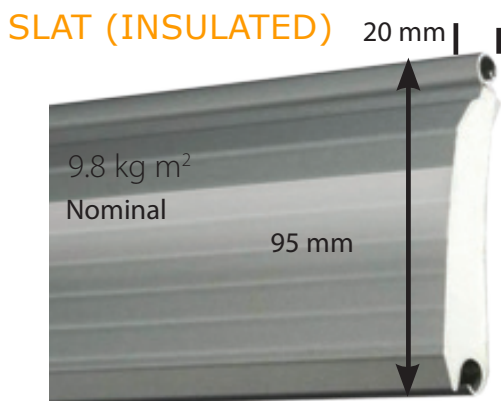
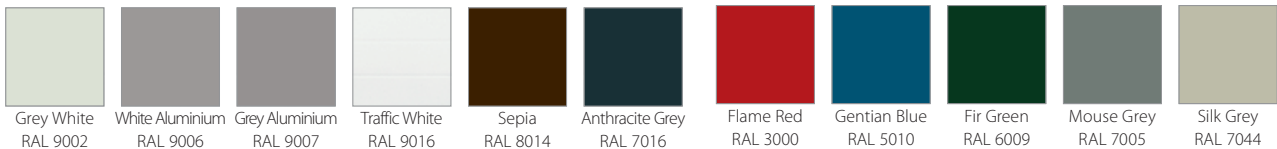



The Insulated Door for Maximum Resistance

A galvanised steel 100mm deep and 23mm thick double skinned CFC free foam insulated curtain construction with a flat design slat.

Max. Width 7000mm

Max. Height 7000mm

Ideal for: Heated buildings, exposed locations, workshops, factories

Wind Class Rating: Class 5

Heat Transmission for slat profile: TBC

Common Options:

Plastisol external face colour options and powder coated colour options

Higher speed motor drive systems for tall openings

Clear perspex vision slat sections at 200mm x 55mm each



THIS PRODUCT CAN BE
POWDER COATED

Please note: that this product will be powder coated after it has been assembled.
Please note: this finish applies to the external face of the curtain slat only.



THIS PRODUCT CAN BE
PLASTISOL COATED

Please note: this finish applies to the external face of the curtain slat only.

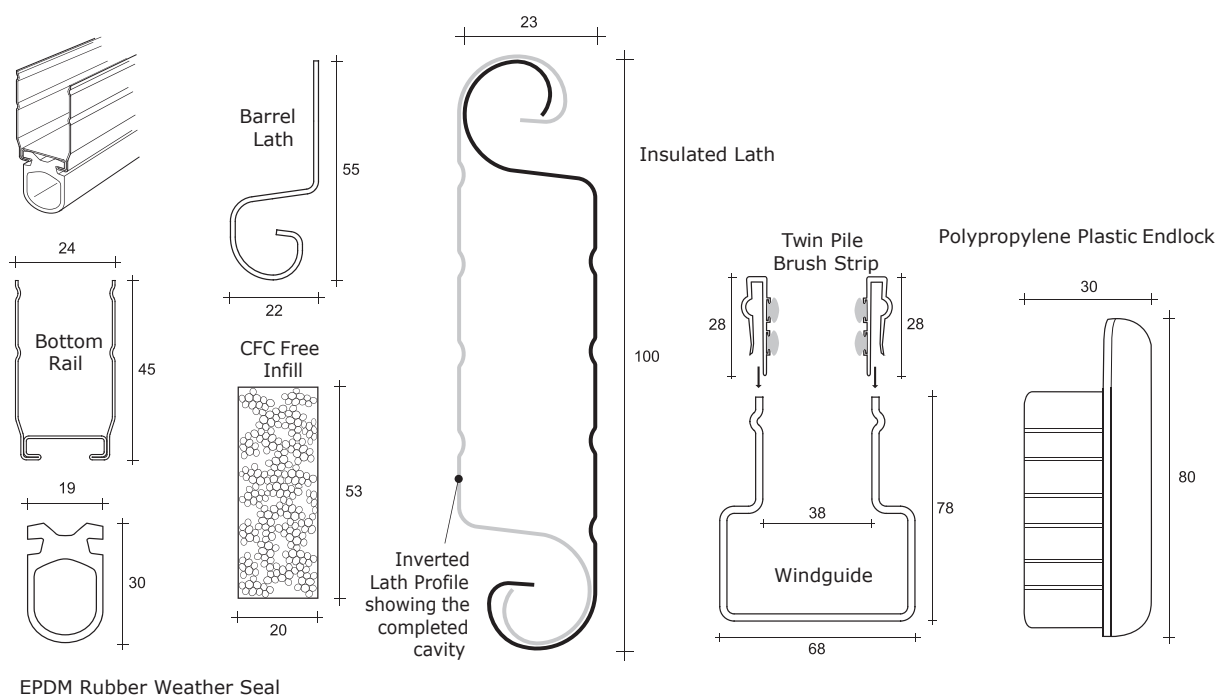



SeceuroDoor 100



SeceuroDoor 95



SeceuroDoor 77



SeceuroDoor 77

Specialised Industrial Roller Doors

Samson offer an even wider range of industrial and commercial roller shutter doors where the specifications are outside the "normal" requirements.



Teckentrup XXL Roller Shutter Door

Teckentrup XXL Roller Shutter Door

A roller door for single door construction up to 18 metres wide and with a central removable transom it can be up to 36 metres wide. Ideal for aircraft hangars, wide warehouse doors and similar. Options on the curtain construction and only available as an electric operation.



ThermoTeck Insulated Roller Door

ThermoTeck Insulated Roller Door

An insulated roller door with many variations in motor drive and insulation levels. Available in heights up to 12 metres high and a very secure and durable roller shutter door.



Hormann SB Roller Door

Hormann SB Roller Door

A spring balanced roller door like no other with a side tension spring system for easy installation and very easy manual emergency override. This is a door system available as a single or very stylish double skinned insulated door in manual or electric operation



Hormann Spiral Door

Hormann Spiral Door – HS 7030PU

A new concept in roller doors, this is a high speed, non contact, insulated roller type door which has panels for curtain more like small sectional door panels. It is a very strong and very durable roller door for hi usage and can operate at up to 2.5m per second. Latest technology in motor drives and controls this is a 21st century door solution where high performance is a must of the building.

Samson

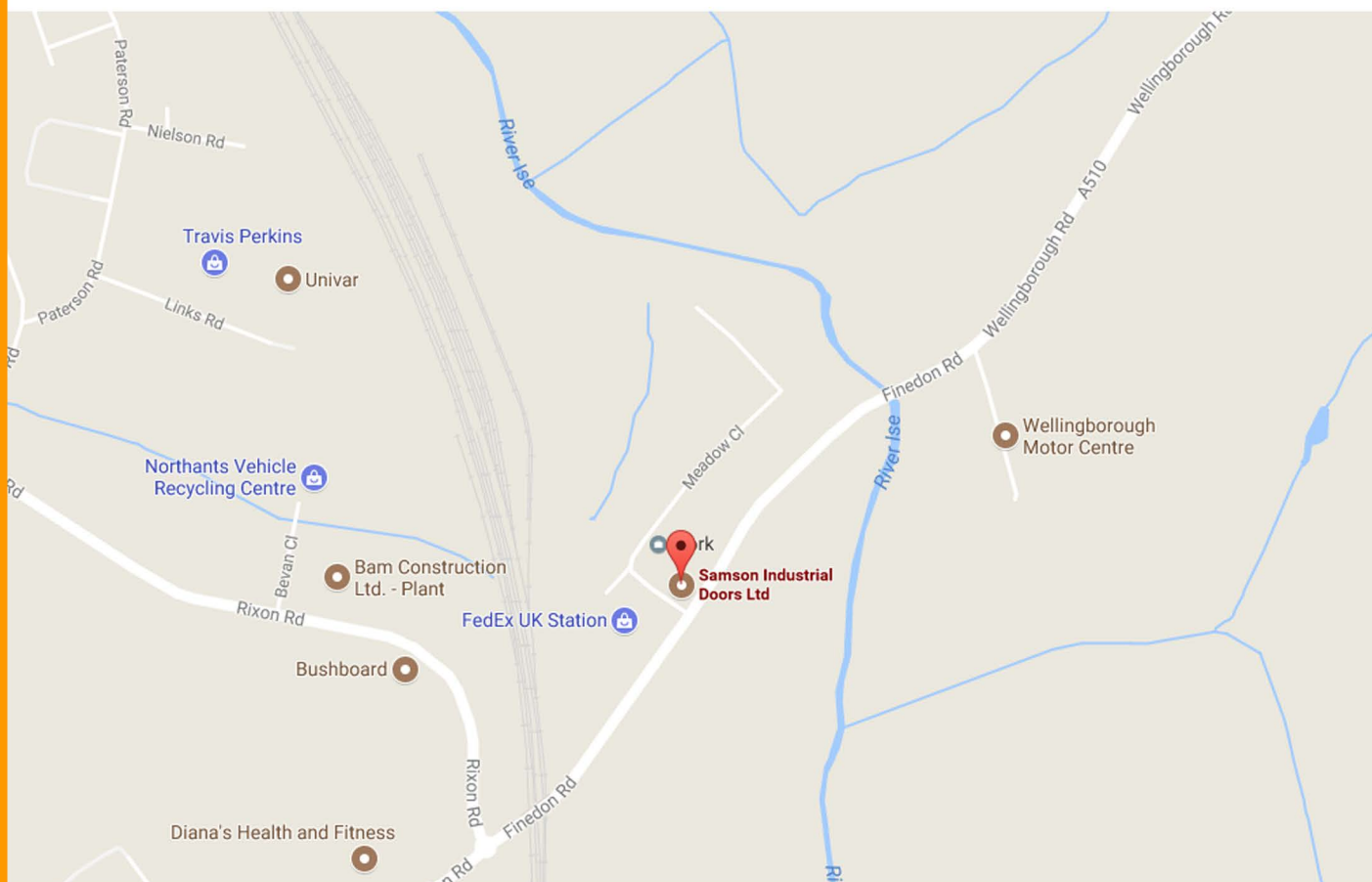

**6-8 MEADOW CLOSE
ISE VALLEY INDUSTRIAL ESTATE
FINEDON ROAD
WELLINGBOROUGH
NN8 4BH**

**EMAIL: ENQUIRIES@SAMSONDOORS.CO.UK
TELEPHONE: (01933) 274276
MON - FRI - 8.30AM - 5.30PM**

