

Samson ThermoTeck Additional Installation Manual

For roller shutter doors with
movable centre column

Valid only in combination with current and
valid installation for industrial roller shutter
doors/grilles

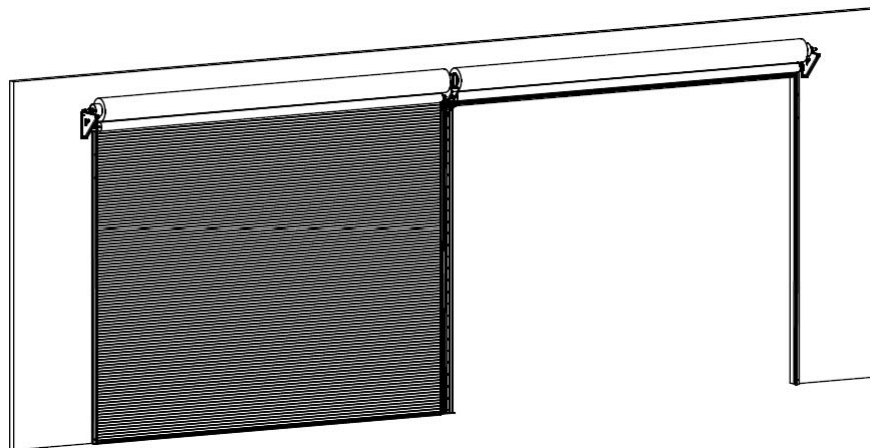

Samson

EMAIL: ENQUIRIES@SAMSONDOORS.CO.UK
TELEPHONE: (01933) 274276
MON - FRI - 8.30AM - 5.30PM

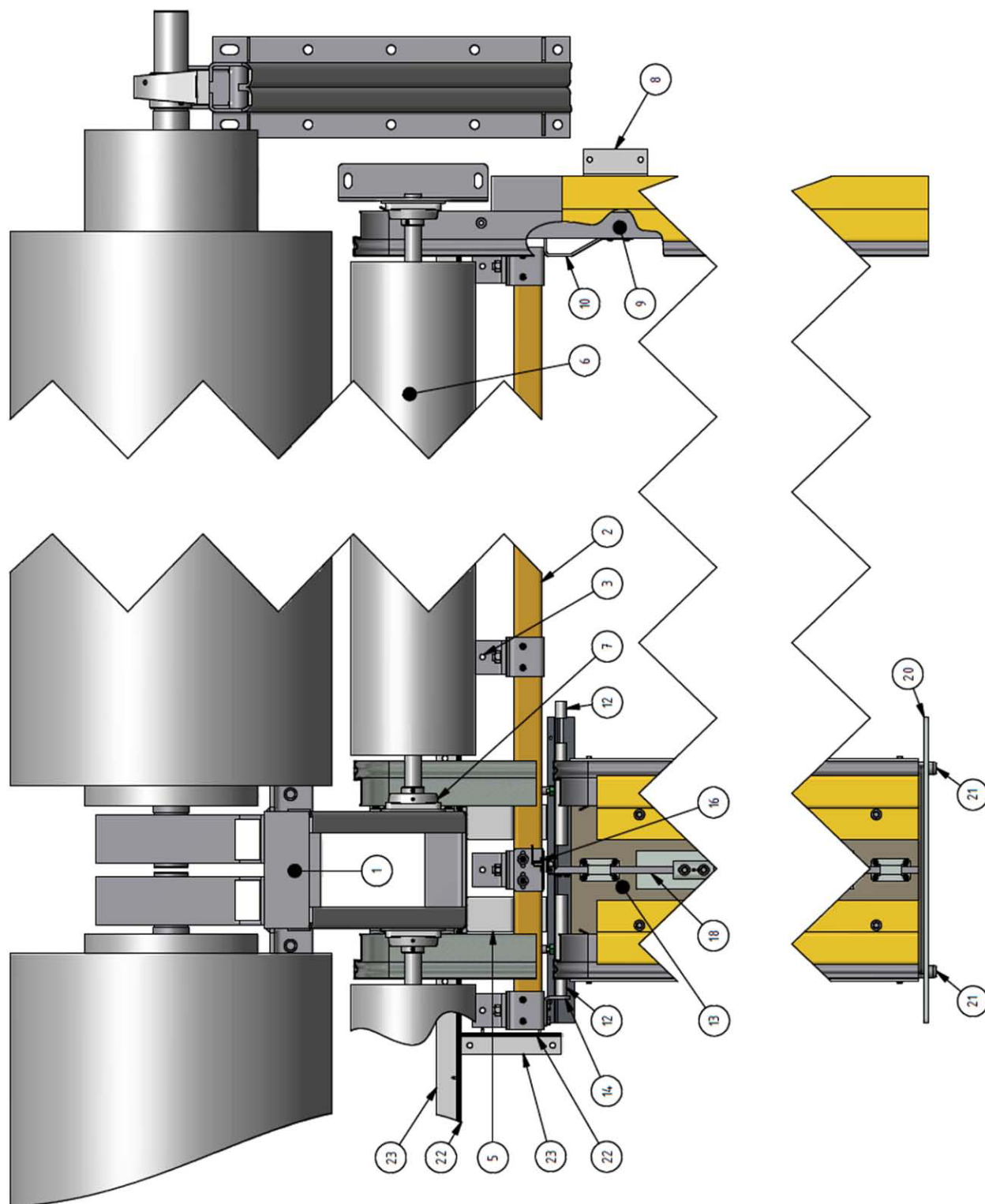

Overview

1. Measure the centre of the centre console (1) at the lintel/building structure. Gauge metre level. Details see drawing.

Please see installation manual for industrial roller shutter doors/grilles 2.0 -5.1

2. Fasten guide rail (2) above the lintel onto the building structure by using retaining brackets (3). If required, connect several guide rails with connecting sleeves (4). Please check drawing for details.

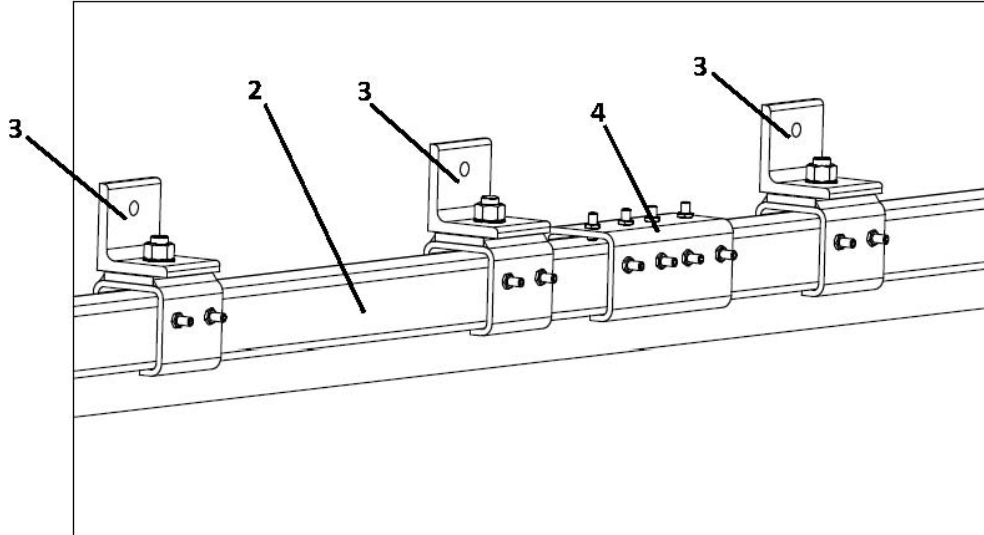

3. Place 2 spacer plates (5) in the area of the centre console behind the guide rail.

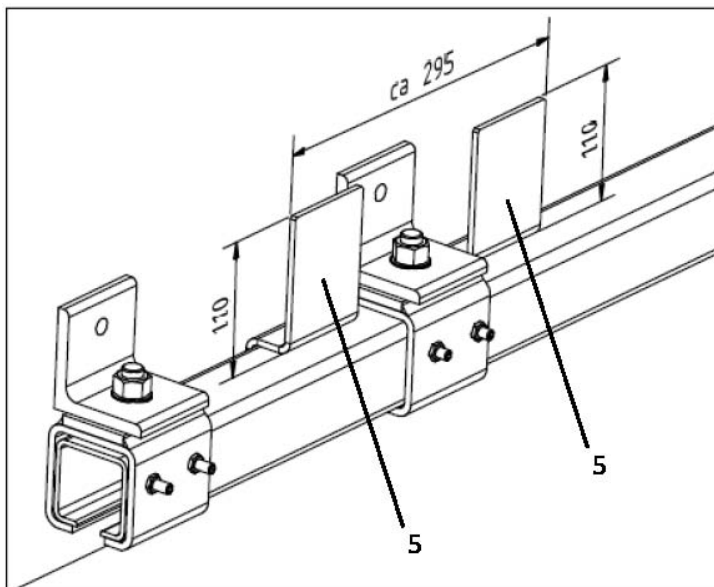

4. Place the centre console (1) with its bottom edge on the spacer plates. Align horizontally and fasten onto the building structure by using the fixing material. Please see drawing for details.

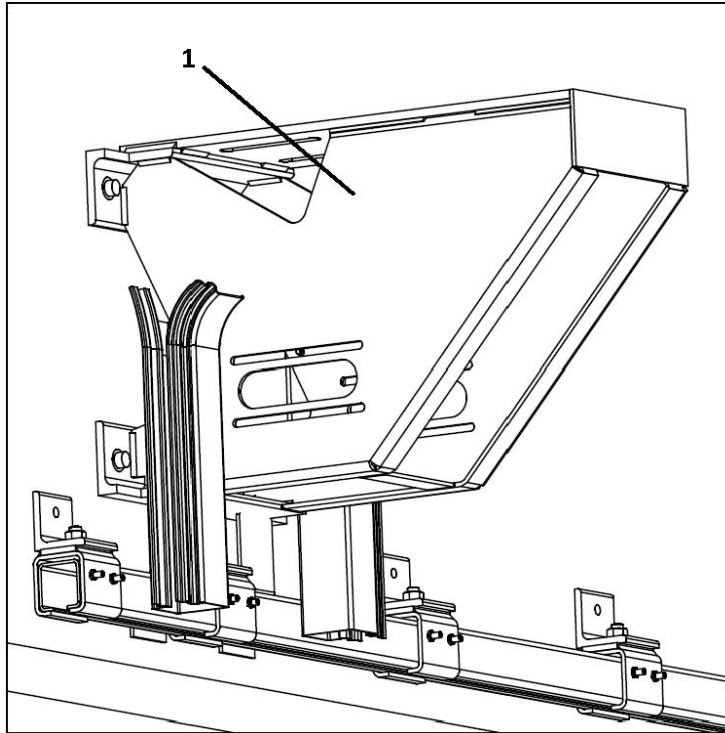

5. Position bearing or anti-drop device on the weld-in shafts of the winding shafts.

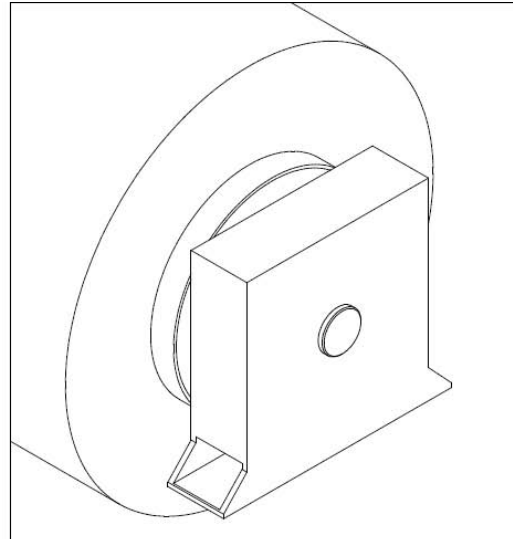
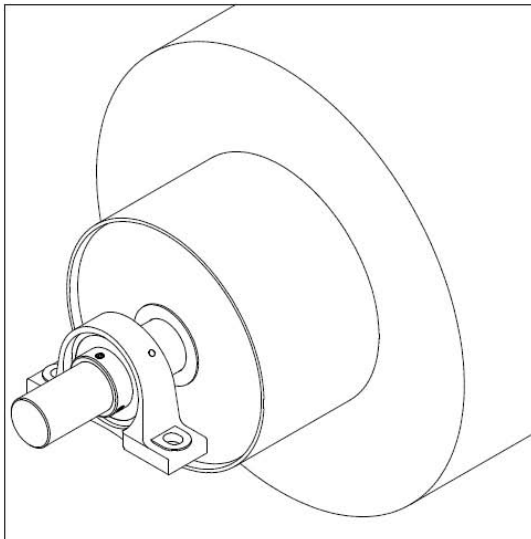

6. For doors $\geq 1,5t$: Put provided round slings around the shaft ends of the winiding shaft/roller curtain, between the two circular blanks. Lift the roller shutter curtain onto the consoles using the round slings and fasten it. Then remove the round slings (cut them into pieces) and dispose them.

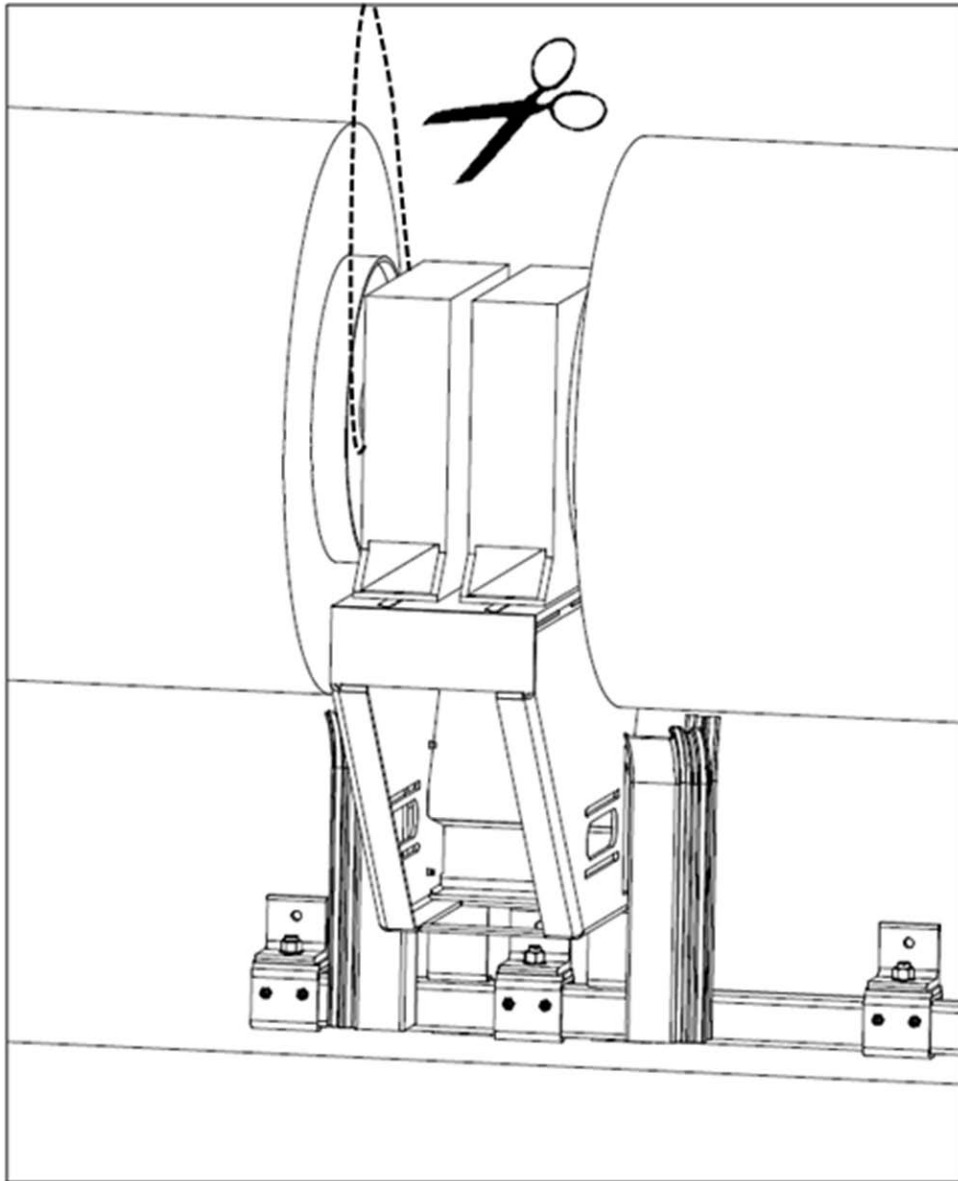

7. Assemble roller shutter door and guide rails according to the manual.
See installation manual for industrial roller shutter doors/grilles 5.2 -5.7

8. If necessary, position the pressure shaft (6) and related bearings (7) and fasten them to the console.
See drawing for details.

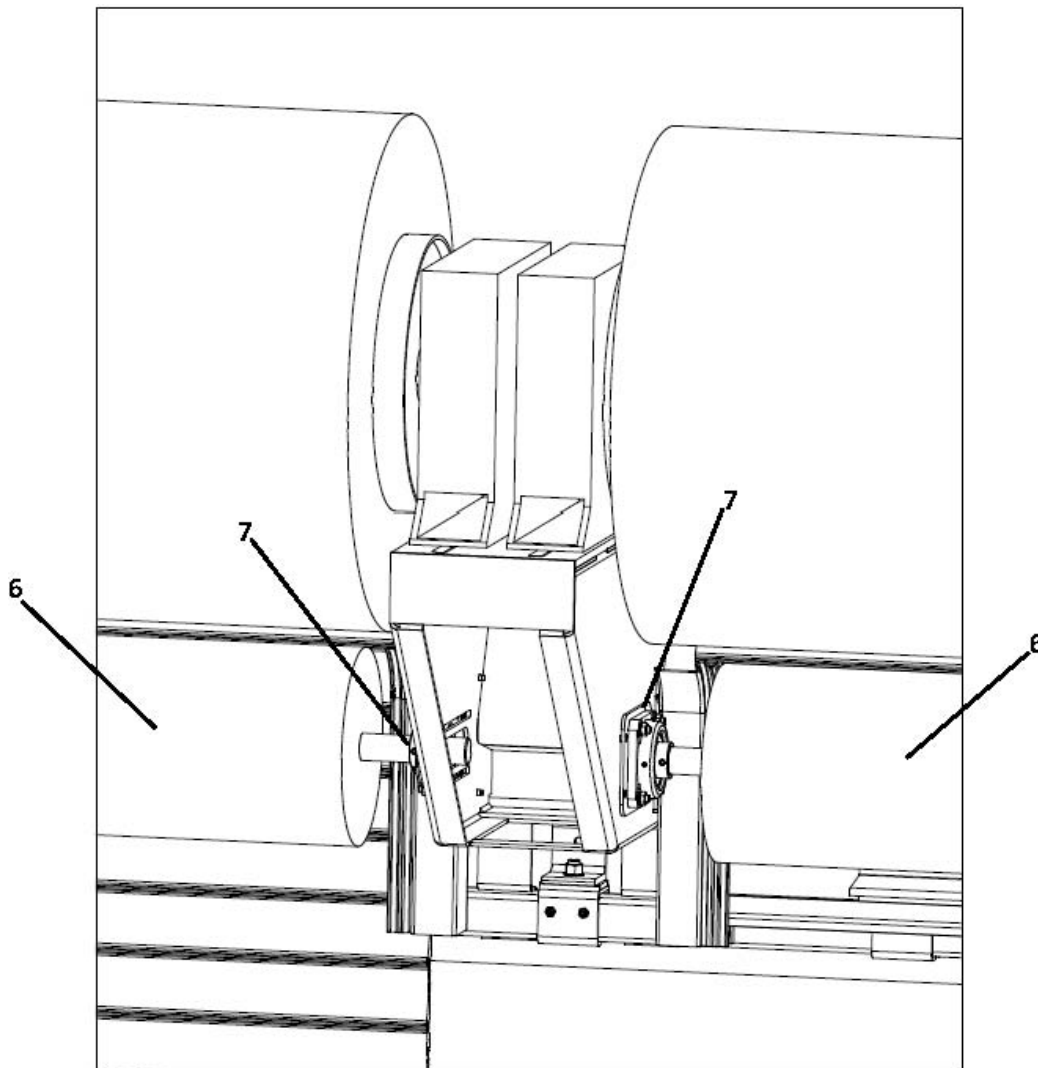

9. Screw the counter retaining brackets (8) in the storage area of the centre column from outside to the relining tube and the wall.

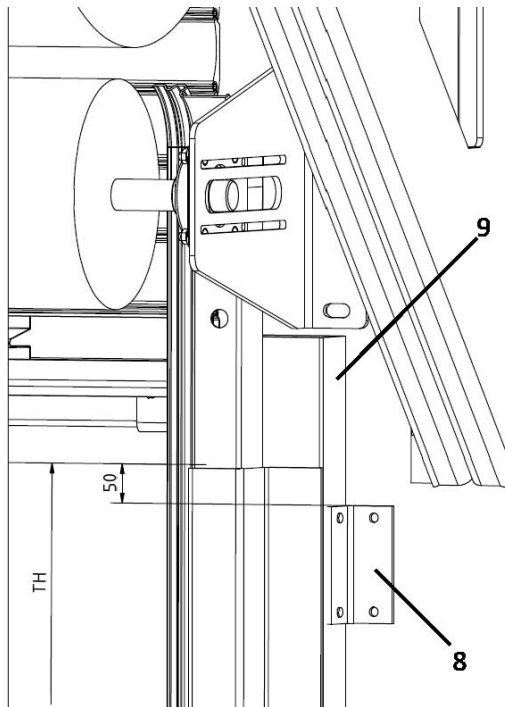

(shown is the right storage area)

10. Fasten the stopper plate (10) in the storage area of the centre columns to the inside of the relining tube.

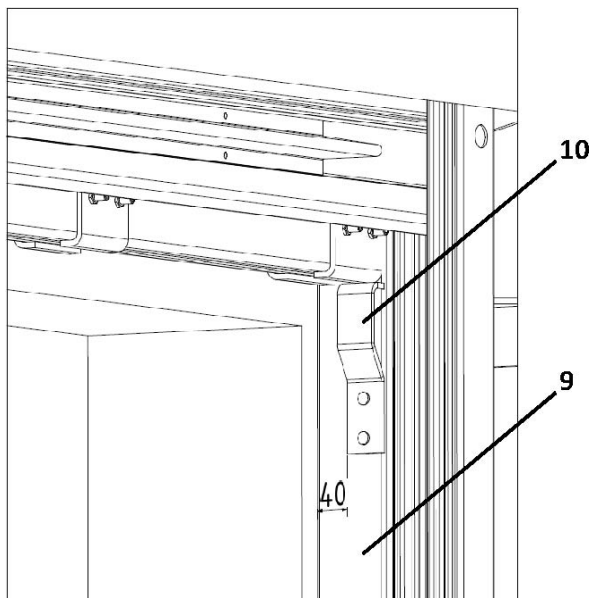

(shown is the right storage area))

11. Fasten reel modules (11) and hydraulic dampers (12) to the centre column (13).
Default position: max. 10mm

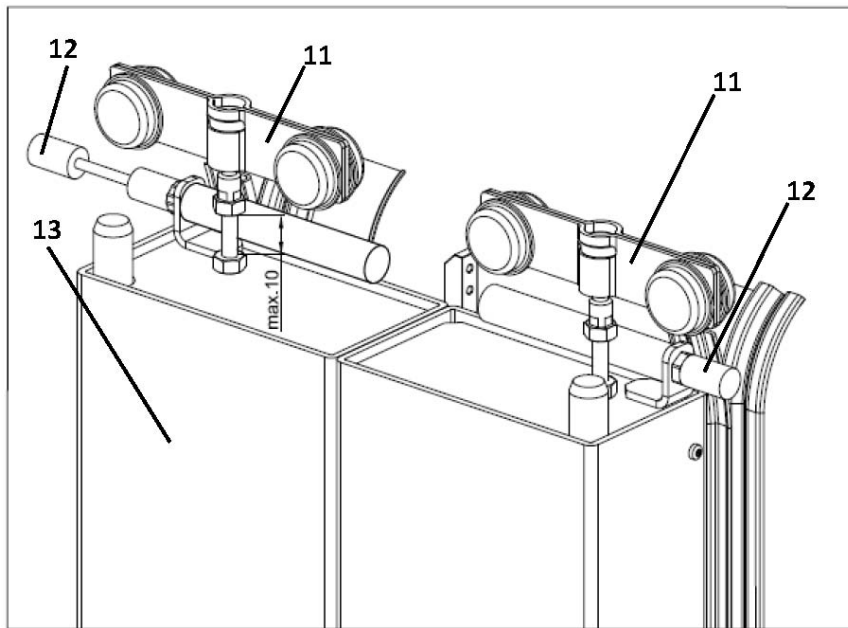

12. Hang the centre column (13) with the reel modules (11) into the guide rails (2), and align/adjust the height accordingly. See drawing for details.

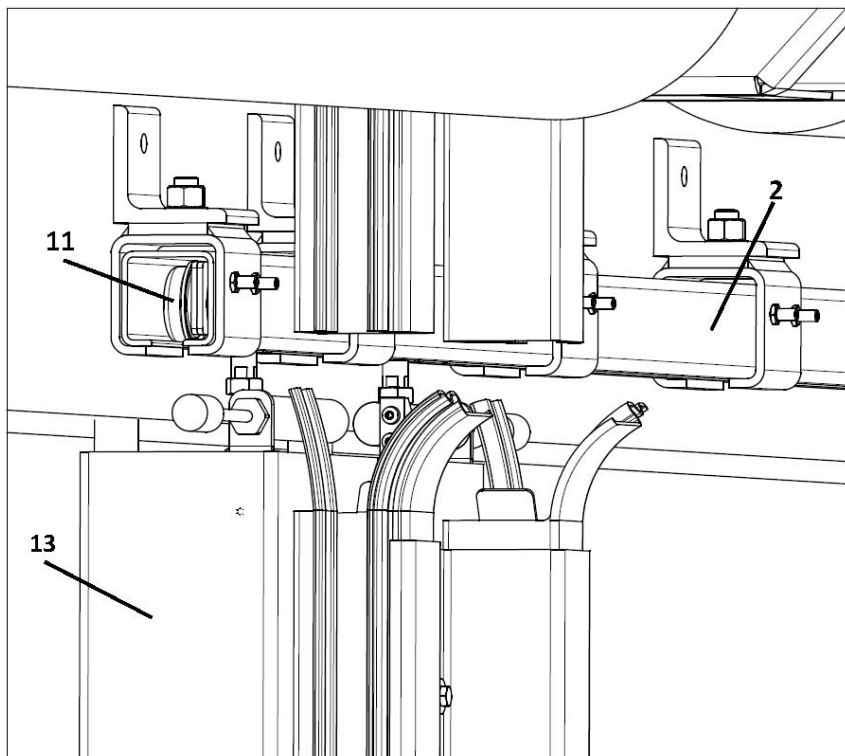

13. Fasten buffer brackets (**14**) for bump stop below the guide rail to the 1. sleeve by using the threaded plate (**15**).

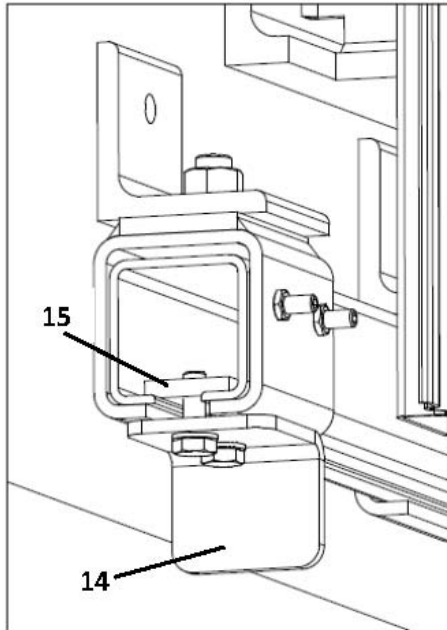

14. Mount the reed contacts (**16**) onto the centre column using the fixing brackets and align the switch flag (**17**) to the lock bar (**18**). Please check enclosed diagram for wiring and connection.

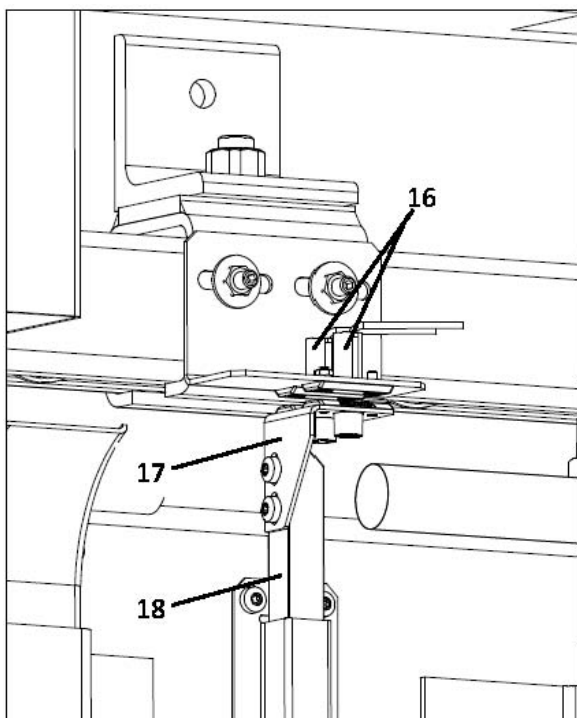

15. Carry out position fine-tuning/readjustment of the centre column, reed contacts, hydraulic dampers and buffer stops.

16. Place, align and fasten lock plate -top (19) to the lintel, and the lock plate-bottom (20) to the floor using the the lock bolts (21).



ATTENTION! The insertion depth of the lock bolts is deeper than the lock plate thickness. Please ensure to create sufficient free space (min. Ø35 x 30deep) in the building structure (lintel and floor).

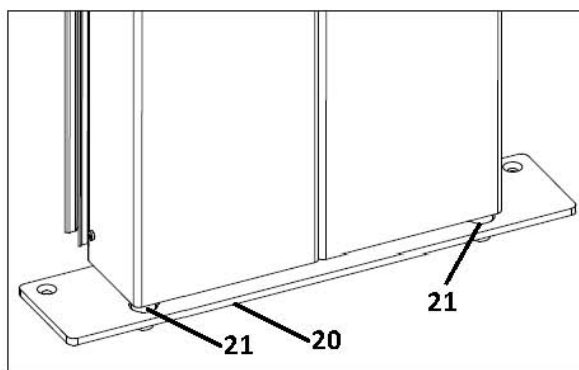
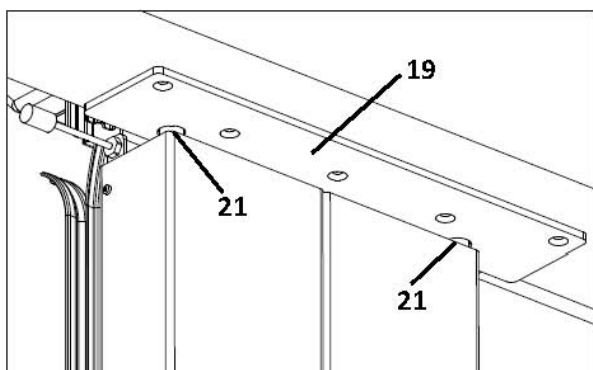

17. Screw together brush strips (22) and brush retaining plates (23) and fasten them to the lintel/ building structure. See drawing for details.

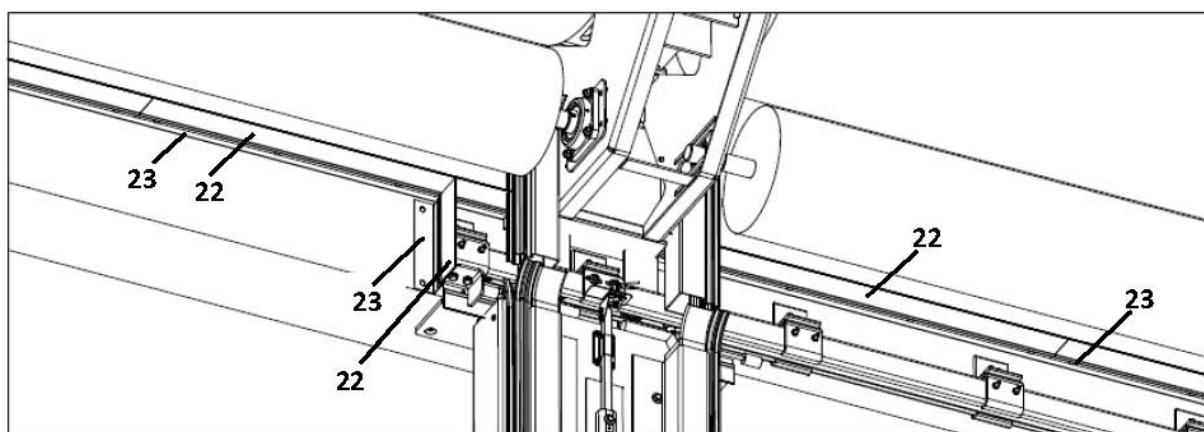

18. Mount the face plate (24) to the centre column by using self-tapping screws.

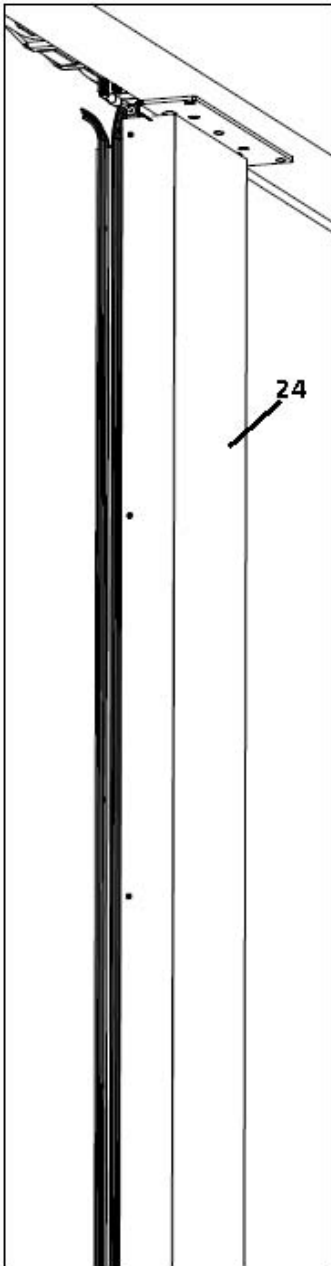

19. Continue/finish the installation according to the installation manual for industrial roller shutter doors/grilles.

See installation manual for industrial roller shutter doors/grilles 5.9 -6.0

Samson

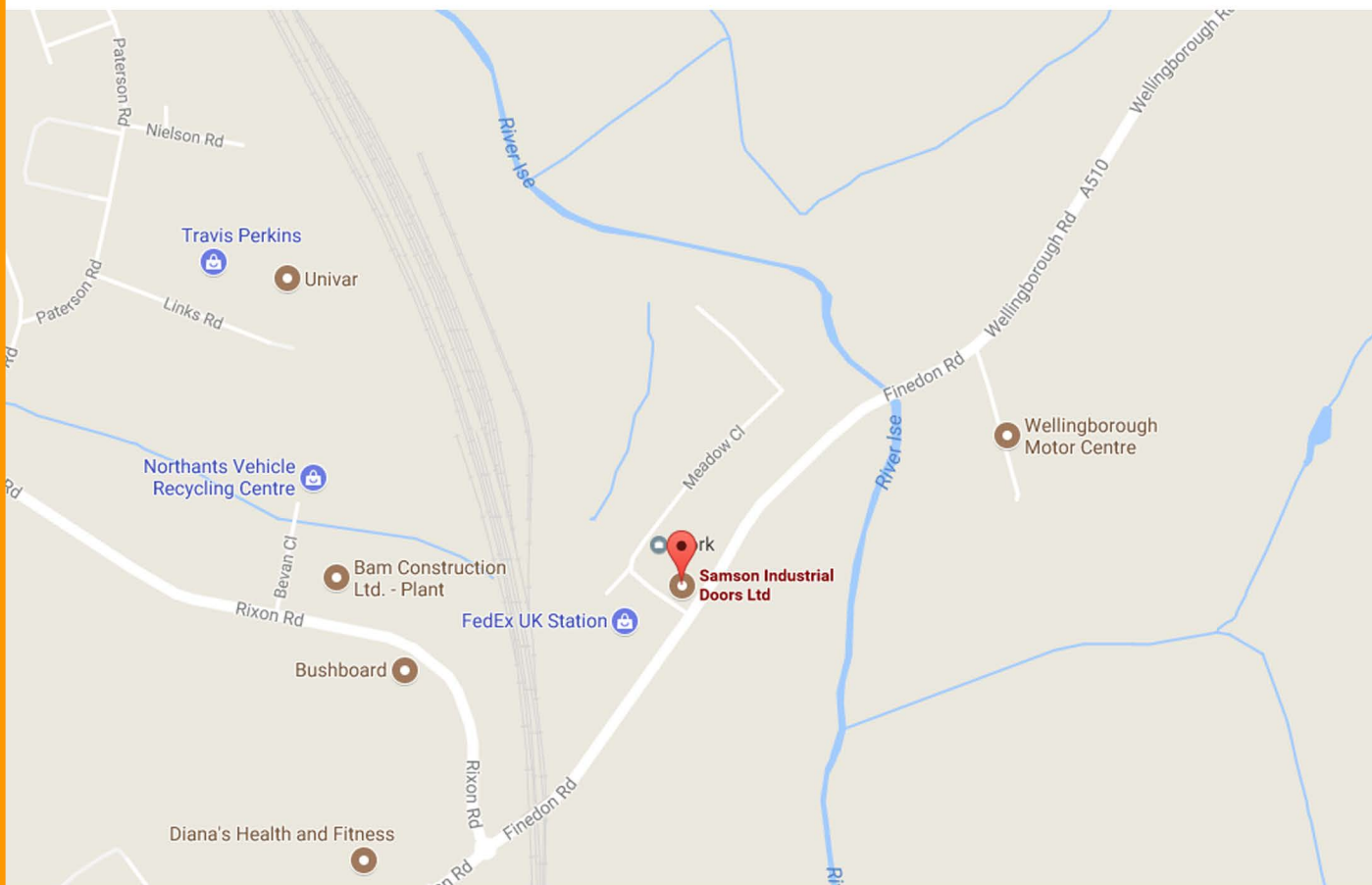

**6-8 MEADOW CLOSE
ISE VALLEY INDUSTRIAL ESTATE
FINEDON ROAD
WELLINGBOROUGH
NN8 4BH**

**EMAIL: ENQUIRIES@SAMSONDOORS.CO.UK
TELEPHONE: (01933) 274276
MON - FRI - 8.30AM - 5.30PM**