

BUILT-ON STEEL COMMERCIAL SECURITY SHUTTERS TECHNICAL GUIDE - TRADITIONAL DESIGN

General

CE Traditional shutter construction employing steel channel and angle guides with electric or manual operation. SECEUROSHIELD 7500 and SECEUROVISION 7500 are compliant with the latest European product directives and standards including BSEN 13241-1 applicable from the 1st May 2005

- Stronger construction, more suitable for larger sizes.
- Endplate attached to angle therefore more suitable for shutters where the headplate requires additional support.
- Sizes, specification and motor rating are designed for window protection, if there is no further protection behind the shutter then maximum sizes must be reduced.

	Max Height (to top of box)	Minimum Overall Width	Maximum Overall Width	Maximum Area
Electric	4.7m	1.0m	6.0m	20m.sqr
Manual	2.8m	1.0m	4.0m	8m.sqr

Guide Channels

- 3mm galvanised steel
- 50mm x 32mm (standard on manual),
- 65mm x 32mm (standard on electric),
- windlock guide at a surcharge.
- Guides belled to aid curtain movement.
- Stops welded to top of guides on both sides on manual shutters.
- On electric shutters the guide on the motor side is spaced off the fixing angle (using 30mm x 30mm galvanised steel box section as standard) to enable easy access to motor limits and override if requested (see fig. 6). 50mm x 50mm steel box section will be used on motors above 120Nm (see fig. 8 + 9).
- On electric shutters, if an anti-drop brake is required, the dummy end side will be spaced off the fixing angle using box section. Up to 150kg 30mm x 30mm box section is used. Above 150kg 50mm x 50mm box section is used.

- 6mm angle will be used for all electric shutters with curtains above 144kg in weight (see chart on page 4).
- Inset angle as standard, outset angle if preferred, please state on order form.

Head Plates

- Guide channels, and 30mm x 30mm box section (electric only) supplied bolted to angle with M8 CSK bolts and M8 nyloc nuts (fig 5). Head plates welded to angle.
- Except reveal fix where 6mm angle is drilled and tapped to accept M8 CSK bolts.
- 3mm galvanised steel, 45 degree chamfered profile.
- On electric shutters that are so large as to necessitate the use of a motor above 120Nm, (see chart on page 4), then the layout of the shutter will differ to standard (fig. 8/9).
 - For reveal fix shutters this will involve using 50mm x 50mm box section to bring the guide, on the motor side, further off the angle (fig. 9).
 - For face fix shutters no box is required to bring the guide off the angle, instead the head plate is offset 50mm from the angle to allow for the larger motor (fig. 8).

Standard Coiled (internal fit)	Reverse Coiled (External fit)	Head Plate Size (mm)
2.0m	1.2m	250 x 250
2.8m	2.5m	300 x 300
3.8m	3.4m	350 x 350
4.7m	4.7m	400 x 400



Detail of Belling and Stops

Stops and lock box only on manual shutters

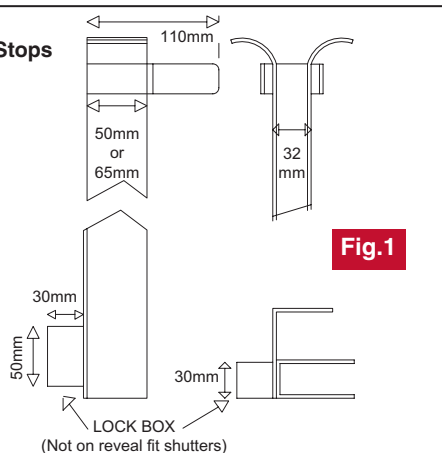

Angle

- 3mm galvanised steel 75mm x 50mm. Drilled for bolting to guides with M8 Nyloc nuts and bolts.
- 6mm galvanised steel 75mm x 50mm supplied for reveal fixed shutters. Angle is drilled and tapped for attachment to guides with M8 bolts.



Traditional Commercial Shutter

Curtain

- 75mm 22swg galvanised solid or perforated slats.
- Curtain is fully endlocked with nylon endlocks. Steel endlocks available at a surcharge.
- Curtain is reverse coiled on external shutters.
- The top three slats on reverse coiled curtains will be reversed to aid rolling of the curtain round the axle.
- Curtain attached to axle with 400mm attachment strips attached to the axle 250mm from each end and then every 500mm with M8 bolts.
- Perforated curtains will have approximately four solid slats at the top of the curtain to aid rigidity.
- Windlocked curtains have a windlock on the third slat up, then every eighth slat up to the middle of the curtain.
- Curtains will be despatched in sections no greater than 50kg.

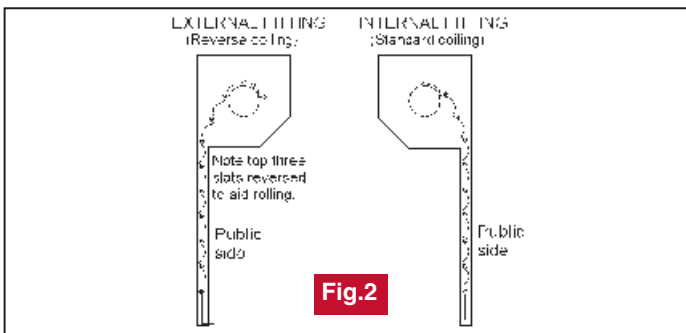

Bottom Slat

- Galvanised L or T section, please indicate on order form.
- T section more secure but has less clearance for handles.

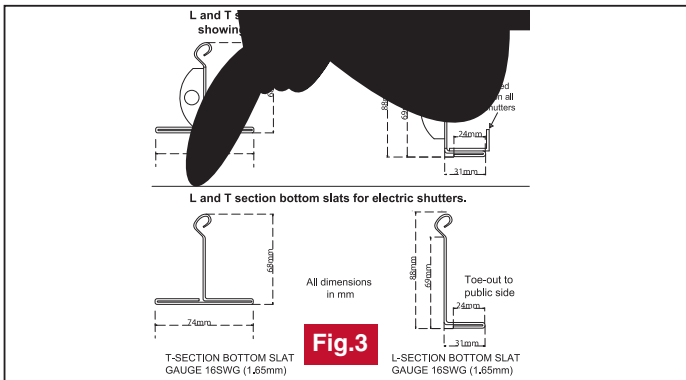

Locks - Electric

- Electric commercial shutters only rely on their own weight to lock, however bullet locks are available at a surcharge if required (not available on windlock guides).
- Optional isolator box highly recommended if bullet locks are used.
- Optional bullet locks are fitted 345mm from the base of the shutter, two keys per bullet lock supplied.

Locks - Manual

- Espagnolette lock in bottom slat as standard. Two keys supplied.
- On face fit shutters using an espagnolette lock, a lock box is welded onto the angles 10mm up from the bottom to accept the lock bar (50mm high, 25mm wide, 30mm deep, see fig. 1)
- Bullet locks available at a surcharge (unavailable on windlock guides).
- Bullet locks welded onto guides 345mm from the base of the shutter. Two keys supplied with each bullet lock.

Axle

- Corrosion treated axle.
- For safety the dummy end of the axle is fixed rigidly to the headplate and turns in the axle.
- The dummy end shaft adjusts by approximately 90mm.
- Anti-fall back devices are required for shutters installed over doorways when the shutter curtain weight exceeds 26.5kg (see charts on back page).

Motor & Controls

- Single phase tubular motor (not suitable for frequent or continuous use).
- Surface mounted internal switch supplied as standard.
- Keyswitches available at a surcharge.
- Maximum current draw is 3Amp.
- Manual override facility can be specified at a surcharge (hook and eye as standard with 1100mm crook).
- Battery back ups are available at a surcharge.
- SeceuroSmart remote control available with bottom slat safety edge. The SeceuroSmart includes a bulk head light and integral controls on the receiver lid.
- SeceuroSmart Professional, hold to run, remote control available without bottom slat safety edge. The SeceuroSmart Professional does not include a bulk head light or integral controls on the receiver lid.
- Anti-drop brakes are supplied as an anti-fall back device when required. The anti-drop brake may include a micro limit switch which will require wiring into the electric control circuit (see charts on back page).



Manual Operation

- The axle is supplied pre-tensioned with a pin locking the axle. (On site adjustment may be required)
- Direction and turns are indicated on the axle.
- We do not recommend springing above the stated maximum size.
- A second spring is supplied as an anti-fall back device when required (see charts on back page).

Hood

- Galvanised steel three sided hood as standard.
- 1mm gauge.
- Two sided hood available if required.
- Available with fascia if required at a surcharge.

Finish

- All external steel components are galvanised.
- Optional plastisol curtain or powder coated finish on components as required (at a surcharge).
- Plastisol finish on curtains will be on external side of shutter.

Installation Notes

- Curtains are despatched in sections and will require assembling on site.
- Due to the nature of commercial slats the curtain level may not always be consistent.
- Commercial slats are designed to roll in both directions. It is therefore not possible to use them to physically lock the curtain down.

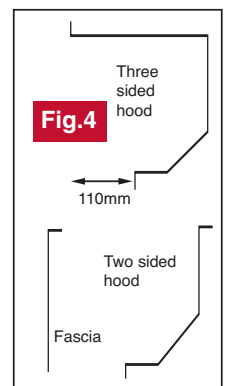

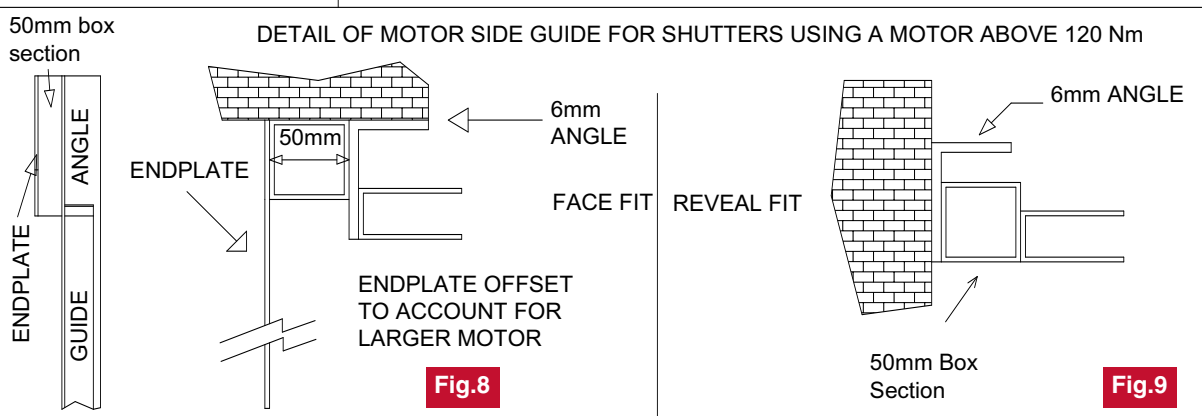
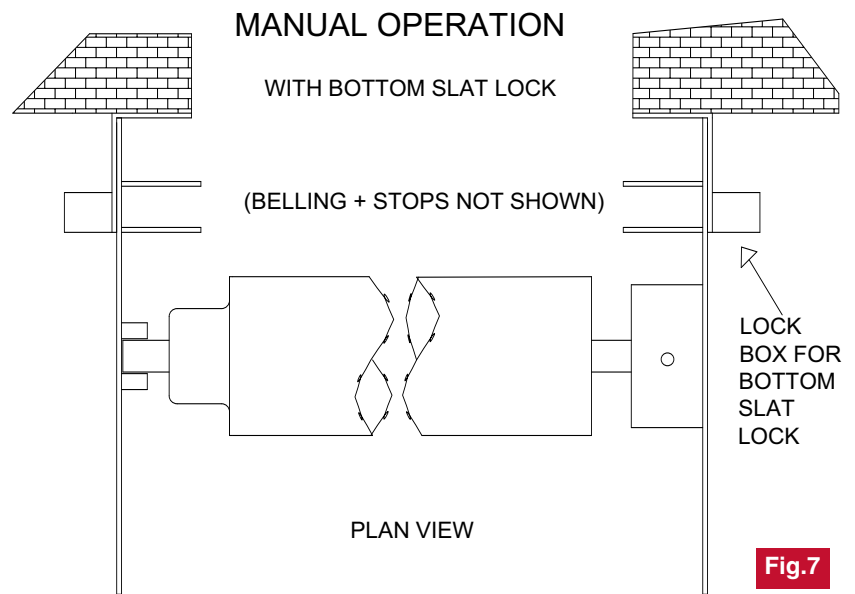
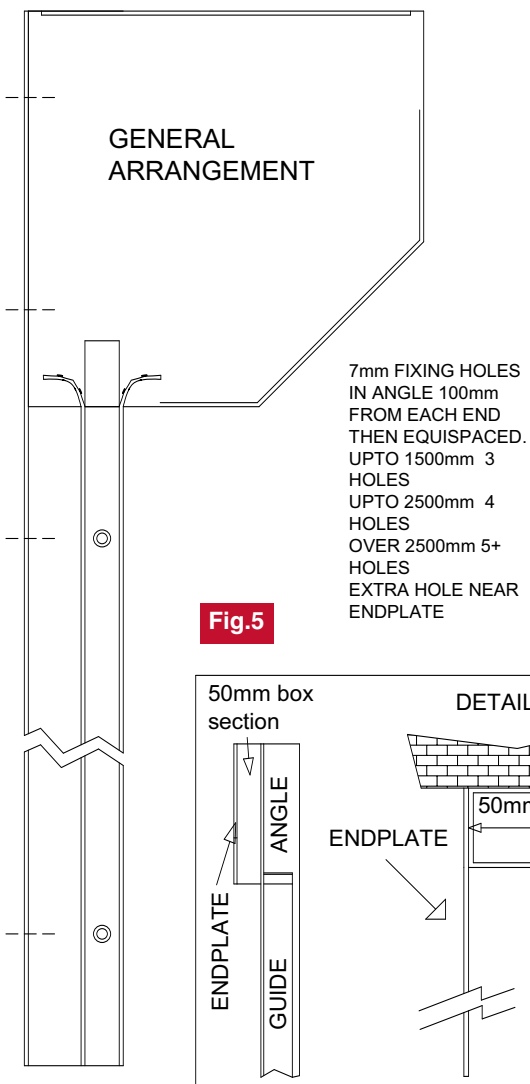
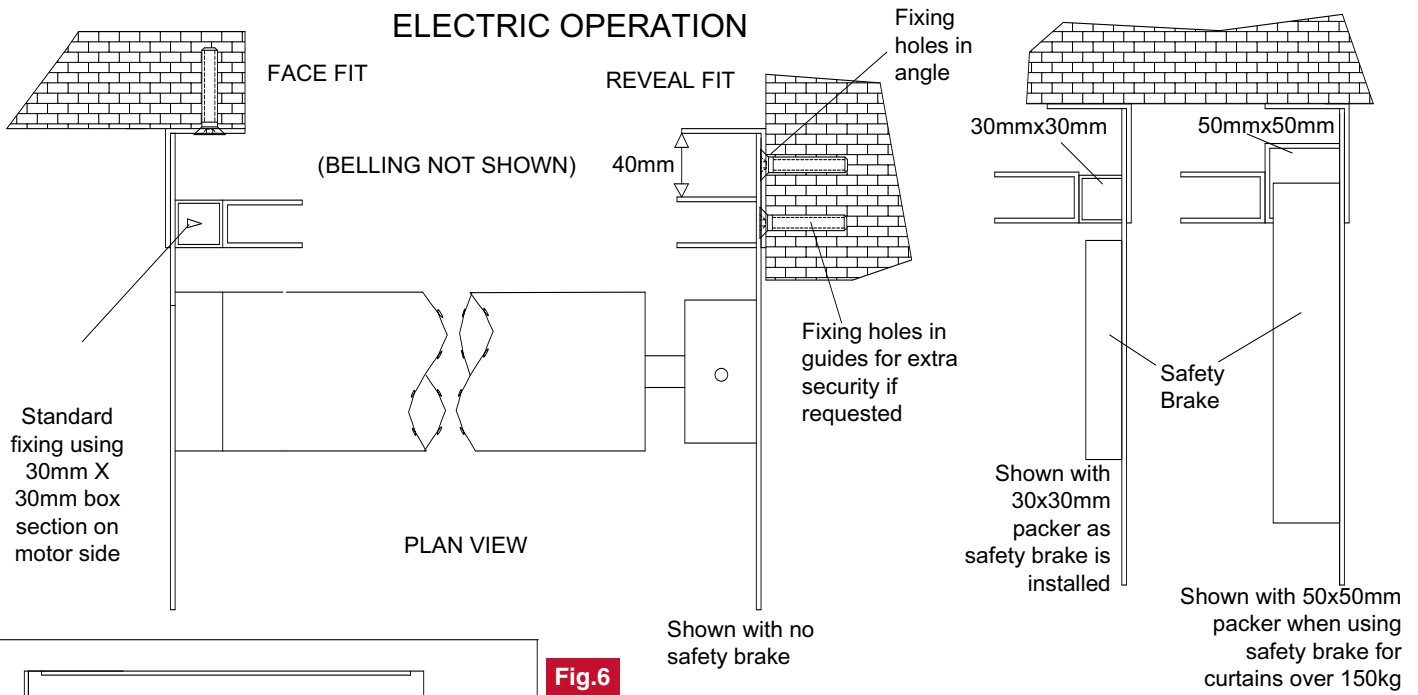

Traditional Commercial Shutters

Manual operation - Solid curtain Width (m)

Box size		Width (m)																Box size		
Internal	Height	10	12	14	16	18	20	22	24	26	28	30	32	34	36	38	40	External	Height	
250 upto 2m	10																	10	250 upto 1.2m	10
	12																	12		12
300 upto 2.6m	14																	14	300 upto 2.5m	14
	16																	16		16
	18																	18		18
	20																	20		20
	22																	22		22
	24																	24		24
	26																	26		26
	28																	28		28

Manual operation - Perforated curtain Width (m)

Box size		Width (m)																Box size		
Internal	Height	10	12	14	16	18	20	22	24	26	28	30	32	34	36	38	40	External	Height	
250 upto 2m	10																	10	250 upto 1.2m	10
	12																	12		12
300 upto 2.6m	14																	14	300 upto 2.5m	14
	16																	16		16
	18																	18		18
	20																	20		20
	22																	22		22
	24																	24		24
	26																	26		26
	28																	28		28

KEY	
	(window) or (door)
	(window) or (door with anti-drop brake)
	window only, can not be a door

Steel electric operation - Perforated curtain Width (m)

Box size		Width (m)																				Box size							
Internal	Height	10	12	14	16	18	20	22	24	26	28	30	32	34	36	38	40	42	44	46	48	50	52	54	56	58	60	External	Height
250 upto 2m	10																					10	250 upto 1.2m	10					
	12																					12		12					
300 upto 2.6m	14																					14	300 upto 2.5m	14					
	16																					16		16					
	18																					18		18					
	20																					20		20					
	22																					22		22					
	24																					24		24					
	26																					26		26					
	28																					28		28					
350 upto 3.2m	30																					30	350 upto 3.4m	30					
	32																					32		32					
	34																					34		34					
	36																					36		36					
	38																					38		38					
	40																					40		40					
	42																					42		42					
	44																					44		44					
400 upto 4.7m	46																					46	400 upto 4.7m	46					
	48																					48		48					
	4.8																					4.8		4.8					
	4.8																					4.8		4.8					

6mm Angle used on traditional shutters due to weight

Design amended due to larger motor

Steel electric operation - Solid curtain Width (m)

Box size		Width (m)																				Box size							
Internal	Height	10	12	14	16	18	20	22	24	26	28	30	32	34	36	38	40	42	44	46	48	50	52	54	56	58	60	External	Height
250 upto 2m	10																					10	250 upto 1.2m	10					
	12																					12		12					
300 upto 2.6m	14																					14	300 upto 2.5m	14					
	16																					16		16					
	18																					18		18					
	20																					20		20					
	22																					22		22					
	24																					24		24					
	26																					26		26					
	28																					28		28					
350 upto 3.2m	30																					30	350 upto 3.4m	30					
	32																					32		32					
	34																					34		34					
	36																					36		36					
	38																					38		38					
	40																					40		40					
	42																					42		42					
	44																					44		44					
400 upto 4.7m	46																					46	400 upto 4.7m	46					
	48																					48		48					
	4.8																					4.8		4.8					
	4.8																					4.8		4.8					

6mm Angle used on traditional shutters due to weight

Design amended due to larger motor

KEY	
	(window) or (door)
	(window) or (door with anti-drop brake)

