

# Steel and stainless steel sliding doors FST

Fire and smoke-tight sliding doors, multi-purpose sliding doors, hinged garage doors  
NEW: Hold-open devices and fire detectors

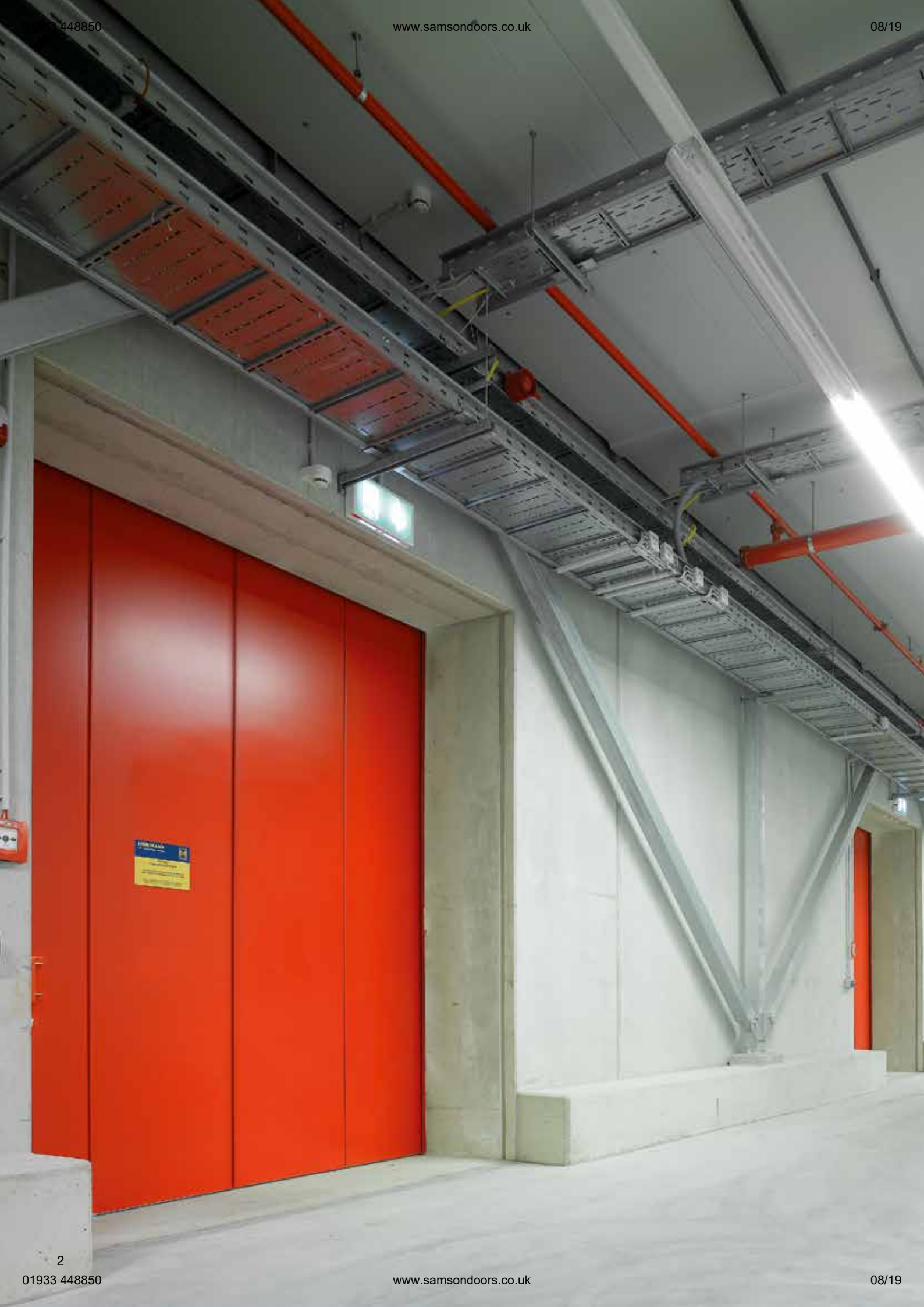





- 4 Brand quality from Hörmann
- 6 Hörmann fire protection elements
- 8 Sustainable production
- 10 Good reasons to try Hörmann sliding doors
- 12 Quality in the details
- 14 Surface finishes and colours
- 16 Fire and smoke-tight sliding doors
- 18 Multi-purpose sliding doors
- 20 Wicket door with trip-free threshold
- 22 Flush-stopping sliding door
- 23 Recess and ceiling flaps
- 24 Operator solutions for sliding doors
- 26 Special equipment
- 28 Hinged garage doors DFT FST
- 30 Horizontal and vertical views
- 32 Sliding doors with wicket door
- 33 Recess and ceiling flaps
- 34 Technical manual
- 38 Hörmann product range

Copyright: No part or excerpt may be reproduced without our prior permission.  
Subject to changes. Some of the doors shown are special versions and may require approval in individual cases.

Hörmann fire and smoke-tight sliding door,  
Bettenwelt GmbH & Co. KG, Zarrentin, Germany

# Hörmann brand quality

## Future-oriented and reliable



Lenkwerk in Bielefeld, Germany, featuring Hörmann products



### In-house product development

Growing and constantly changing functional and safety requirements necessitate continuous new construction / equipment developments and improvements, especially when it comes to moveable construction components such as doors. In this area, our qualified development teams time and again prove their great specialised expertise.



### Highly sophisticated production methods

We at Hörmann rely on the latest production technology at our specialised factories. Computer-controlled operations ensure dimensionally accurate elements with perfectly fitted fittings and functional parts.



As Europe's leading manufacturer of doors and frames, we are committed to high product and service quality. This is how we set standards on an international scale.

Highly-specialised factories develop and manufacture construction components that are marked by excellent quality, functional safety and a long service life.

Our presence in the global economy's key regions makes us a strong, future-oriented partner for industrial and public construction projects.



### Fire testing centre with test laboratory

Our new and further developments are constantly tested for the required fire resistance and smoke-tightness through in-house fire tests at our fire testing centre. The knowledge gained from these tests ensures high fire protection for buildings. They also allow us to optimally prepare our innovations for the official inspections by the authorised test centres for official approvals.



### Expert building support

Experienced specialists of our customer-oriented sales organisation support you from the planning stage, through technical clarification up to the final building inspection.

Expert fitting is guaranteed by experienced Hörmann fitters and the specialised trained staff of Hörmann's partners.

# Hörmann fire protection elements

The right solution for any requirement



## Europe's largest fire protection programme



### Steel and stainless steel construction project doors

Steel and stainless steel multi-function doors offer crucial advantages for architects and building owners: Doors with different functional requirements that are fitted in the same storey match perfectly thanks to their identical look. Steel and stainless steel doors STS / STU feature a flush-fitting, elegant appearance as well as unlimited colour options and many frame variants.



### Multi-function doors

They are characterised by their matching appearance. The advantage for architects and building owners: Doors that fulfil different functional requirements and are fitted on the same floor are perfectly matched to one another.



### Fully glazed tubular frame parts and automatic sliding doors

Hörmann aluminium and steel fire-rated and smoke-tight doors and glazings in the T30, T60 and T90 models will convince you with certified safety, perfect function and a 100 % matching door appearance. With Hörmann automatic sliding doors, you are combining the transparency of tubular frame parts with the requirements of fire protection and barrier-free construction. These products allow Hörmann to provide a uniform fire protection concept for use in architecturally demanding construction projects.



### Visibility windows

Hörmann visibility glazings are used as windows or room-high elements to provide more light and better visibility. Visibility glazing is available for requirements like heat and acoustic insulation or radiation protection. All versions are offered in fire-retarding F30 and fire-resistant F90 variants. Individual solutions can be implemented using rail divisions, recesses and angles.

# Sustainably produced

## For trend-setting construction



### Sustainability documented and approved by the ift in Rosenheim

Hörmann received confirmation of sustainability through an environmental product declaration (EPD)\* in accordance with ISO 14025 from the Institut für Fenstertechnik (ift – Institute of window technology) in Rosenheim. The inspection was based on the Product Category Rules (PCR) Doors and Gates from ift Rosenheim GmbH, issue PCR-TT-0.1. Environmentally-friendly production was confirmed by a life-cycle analysis in accordance with DIN ISO 14040 / 14044 for all sliding doors.

### Sustainably produced fire-rated and smoke-tight elements from Hörmann

**Environmentally friendly production**  
A comprehensive energy management system ensures environmentally-friendly production.

**Regional raw materials**  
The majority of applied raw materials are purchased from Germany and Central Europe.

**Long-lasting products**  
A long service life and low maintenance costs thanks to the use of high-quality materials.

### Sustainable construction with Hörmann's expertise

Hörmann has been able to gain great expertise in sustainable construction through various projects. We also apply this know-how to support your projects.

\* For more information please visit our Internet site at [www.hoermann.co.uk/documentation](http://www.hoermann.co.uk/documentation)



# Simple and sustainable planning

## With Hörmann's Architect's Program



### The Architects' Programme

More than 9000 drawings for over 850 products

Planning with Hörmann products is now even easier thanks to a modern, user-friendly interface. Clearly structured navigation via drop-down menus and symbols, as well as a search function, provide faster access to texts for invitation to tenders and drawings (in DWG and PDF format) of over 850 Hörmann products. **In addition, BIM data can be provided for many products for the Building Information Modelling process, enabling efficient planning, drafting, construction and management of buildings.** Photos and photo-realistic presentations provide additional information on many products.



The Architects' Program is available to you as a web version at [www.hormann.co.uk/forums/architects-forum/architects-program](http://www.hormann.co.uk/forums/architects-forum/architects-program) or can be downloaded free-of-charge from the Hörmann Architects' Forum.



We are a member of the professional association for digital building products in the Federal Association of Building Systems e.V.

## Good reasons to try Hörmann

High-quality versions for the project sector;  
functional solutions for the industrial sector



# 1

### High-quality door appearance

Hörmann sliding doors offer a modern door appearance through a patented V groove at the element joint without visible screw connections. The high stability is ensured through the interlocked, toothed labyrinth plug-in profile. The elements are 72 mm wide, fully glued and flush, and aligned with each other through threaded rods. This creates a high-quality door leaf with parallel, uniformly wide edges. The individual elements are up to 9 m high and are produced from a single piece without any unattractive weld seams.

# 2

### Precise door leaf guide

The cylindrical track roller and the stable track roller, in conjunction with the patented track, work together to provide an optimal force balance. Quiet operation and easy actuation is ensured, thanks to a suspension with ball-bearing. The track can be precisely adjusted in three dimensions using adjusting screws. A track panel in the colour of the door leaf results in a harmonious overall appearance.



**Only from Hörmann**

Combination with the operators  
SupraMatic HT and ITO 400

# 3

## Flush-stopping without guiding profile

This optional door version is an alternative to double-leaf hinged doors in construction projects, e.g. in entrance areas. The clear passage is extended, since the door in the inlet area stops flush with a stainless steel fascia on the wall, ensuring that the elegant appearance is not compromised by a guiding profile. If the parking area is designed as a recess solution with recess flap, the door is practically invisible. Security is ensured through spring-loaded stainless steel guiding bolts, intumescent coating and rubber double seal.

# 4

## With a convenient operator solution

A combination of a steel or stainless steel sliding door with a SupraMatic HT or ITO 400 operator allows for fast opening and closing in daily operation. The operators SupraMatic HT and ITO 400 FU with soft start and soft stop as standard are recommended for a particularly gentle and quiet door travel. The door can be conveniently operated via a hand transmitter, push button or key switch. In case of fire, a patented mechanism is used to unlock the operator. The door is then reliably closed via weights.

# Quality in the details

High-quality door construction for demanding architecture



**Approved and certified in accordance  
with EN 12605 class C5 (long-term function tests  
with 200000 door cycles)**



**1 Slim overall construction**

- Depth of only 132 mm
- Recess width for recess flaps: 180 mm to max. 380 mm

**2 Track panel**

- Matches the door leaf
- Galvanized, RAL to choose or stainless steel
- Easy fitting with few screw connections

**3 Closing weights**

- Easy fitting and maintenance with screw-on weights
- Galvanized or stainless steel

**4 Guiding profile / centring device**

- Centring device for precise door guidance in the guiding profile

**5 Damper**

- Galvanized or stainless steel
- Integrated into door leaf for single-leaf EI<sub>2</sub>30 fire sliding doors
- T30 doors: A damper is not required for door sizes up to 9 m<sup>2</sup>

**6 Integrated floor track roller**

- Horizontally adjustable
- Concealed in door leaf after fitting

**7 Hydraulic track control**

- For continuously adjustable closing speeds (0.08 – 0.2 m/s)
- Invisibly integrated into the weight box

**8 Wicket door**

- Without threshold for escape routes acc. to DIN EN 179 and EN 1125
- With 22 mm threshold for additional stability and for ascending floors or parking ramps, e.g. in underground garages

**Wicket door monitoring via radio**

- Concealed radio magnetic contact in the wicket door
- No possibility of operational damage
- Optional spiral cable and socket at the end of the door leaf with concealed cable routing in the door leaf

**9 Glazing in wicket door and door leaf**

- Maximum glass size of 500 mm × 1000 mm
- Glazing size: 468 mm × 815 mm as standard

**10 Grip and**

**11 recessed handles**

- High-quality stainless steel version as standard

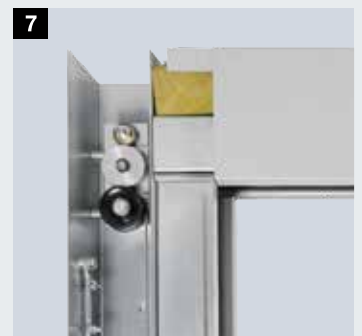

# Surface finishes and colours

## Galvanized, colour-coated or stainless steel

### Surface finishes and colours

The flush and fully bonded sliding doors are delivered in galvanized sheet steel as standard. For the door leaf and door leaf on the wicket door you can choose between the standard Pearlgrain and smooth sheet steel surfaces. The frame parts are supplied with a smooth surface in both versions. For a harmonious door appearance, the doors including frame parts are optionally available in primed Grey white RAL 9002 or with powder-coated primer in 7 preferred colours, RAL to choose, metallic colours or NCS colours and as an exclusive powder coating in Corten steel. We can also provide you with frame parts in an inexpensive, galvanized version for coloured doors on request.

### Stainless steel version

For special visual or construction requirements, doors in stainless steel V2 A, 1.4301 with a 240 K grain size are available. All components, such as the door leaf, tracks, cladding, weight boxes, cables, rollers and support brackets are made of stainless steel. We also deliver optional closing weights in stainless steel V2 A, 1.4301.

Additional versions on request.



We can also provide you with frame parts in an inexpensive, galvanized version for coloured doors on request.

### Door leaf design

- 1** Fire protection material
- 2** Fully bonded
- 3** Optional galvanized sheet steel: stainless steel V2 A, 1.4301
- 4** Optional: Priming in RAL 9002 or primer powder coating in 7 preferred colours or in RAL to choose, metallic colours or NCS colours and as an exclusive powder coating in Corten steel

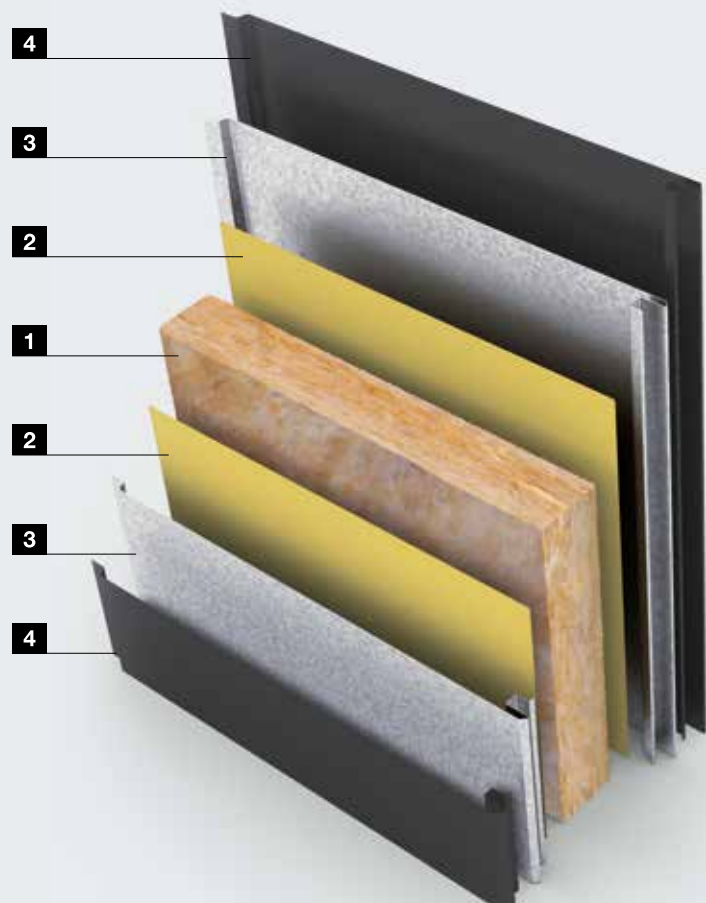

**Pearlgrain version**  
**A robust and highly resistant surface finish**  
**for warehouses and high-traffic areas**

## Surface finishes

**Only from Hörmann**



Pearlgrain, galvanized



Smooth sheet steel, galvanized



Stainless steel V2 A, 1.4301, K 240

## Priming



Grey white

RAL 9002

## Preferred colours



Flame red

RAL 3000



Anthracite grey

RAL 7016



White aluminium

RAL 9006



Grey aluminium

RAL 9007



Pure white

RAL 9010



Traffic white

RAL 9016



### RAL to choose

We also supply all doors optionally in RAL to choose, metallic colours, or NCS colours.



### Corten steel // NEW

For an exclusive view, all doors are available in the high-quality powder coating with the visual and tactile effect of Corten steel.

All colours based on RAL.

# El<sub>2</sub>30 / El<sub>2</sub>90 fire and smoke-tight sliding doors FST

## Single-leaf, double-leaf and telescopic versions

**T30****Fire-retarding**

Single-leaf  
Double-leaf  
Telescopic, double, triple

**El<sub>2</sub>30****T90****Fire-proof**

Single-leaf  
Double-leaf  
Telescopic, double, triple

**El<sub>2</sub>90****RS****Smoke-tight**

Single-leaf  
Double-leaf

**S<sub>200</sub>****dB****Acoustic rating**

El<sub>2</sub>30: up to 29 dB  
El<sub>2</sub>90: up to 31 dB

**Wicket door**

Single-leaf  
Double-leaf  
Telescopic

**Stainless steel**

V2 A, 1.4301

**Further Information**

- Surface finishes / colours page 14
- Operators page 24
- Wicket doors page 20
- Special equipment page 26



## Convenient operator solutions with the optional SupraMatic HT and ITO 400 operators

Door type	Single-leaf	Double-leaf*	Telescopic
<b>T30 / EI<sub>2</sub>30 fire-retarding</b>			
Width (mm)	1000 – 8500	2000 – 8500	2000 – 8500
Height (mm)	2000 – 6000	2000 – 6000	2000 – 6000
Acoustic rating	Up to 29 dB (for all versions)		
<b>T90 / EI<sub>2</sub>90 fire-proof</b>			
Width (mm)	1000 – 8000	2000 – 8000	2000 – 8000
Height (mm)	2000 – 6000	2000 – 6000	2000 – 6000
Acoustic rating	Up to 31 dB (for all versions)		
<b>RS smoke-tight**</b>			
Width (mm)	1000 – 3000***	2000 – 3000***	
Height (mm)	2000 – 4500***	2000 – 4500***	
<b>Minimum door sizes with wicket door</b>			
Width (mm)	1650	2750	3500
asymmetrical division of leaves			
Height (mm)	2100	2100	2100
asymmetrical division of leaves			
Width (mm)	1650	3500	
symmetrical division of leaves			
Height (mm)	2100	2100	
symmetrical division of leaves			

\* Division in width left / right at least 1000 mm

\*\* With wicket door, max. 20 m<sup>2</sup>

\*\*\*Max. size RS smoke-tight 7000 × 4500 mm (width × height) possible with case-by-case approval

**Important:** Larger door heights and widths possible on request and with approval in individual cases. Max. door height 9000 mm manufactured from one piece.

### Wicket door

Standard size (standard)	
Width (mm)	1000
Height (mm)	2000
<b>T30 / EI<sub>2</sub>30 fire-retarding</b>	
Width (mm)	625 – 1200
Height (mm)	1750 – 2000
<b>T90 / EI<sub>2</sub>90 fire-proof</b>	
Width (mm)	625 – 1050
Height (mm)	1750 – 2000
<b>RS smoke-tight</b>	
Width (mm)	625 – 1000
Height (mm)	1750 – 2000

### Single-leaf

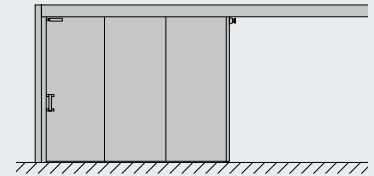

### Double-leaf

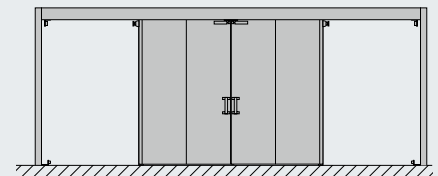

### Telescopic sliding door

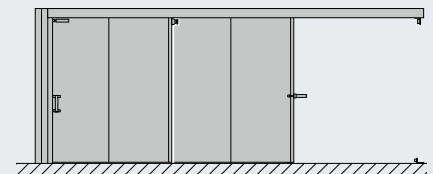

### Wicket door

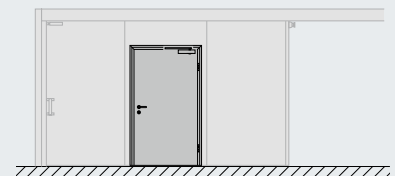

# Multi-purpose sliding doors FST MZ

## Single-leaf, double-leaf and telescopic versions

**MZ****Multi-purpose**

Single-leaf  
Double-leaf  
Telescopic, double, triple

**dB****Acoustic rating**

With mineral wool infill up  
to 29 dB

**Wicket door**

Single-leaf  
Double-leaf  
Telescopic

**Stainless steel**

V2 A, 1.4301

**Further Information**

- Surface finishes / colours page 14
- Operators page 24
- Wicket doors page 20
- Special equipment page 26

Door type	Single-leaf	Double-leaf*	Telescopic
<b>MZ multi-purpose</b>			
Width (mm)	1000 – 12000	2000 – 9000	2000 – 12000
Height (mm)	2000 – 9000	2000 – 9000	2000 – 9000
Acoustic rating	Up to 29 dB (with mineral wool infill)		
<b>Minimum door sizes with wicket door</b>			
Width (mm) asymmetrical division of leaves	1650	2750	3500
Height (mm) asymmetrical division of leaves	2100	2100	2100
Width (mm) symmetrical division of leaves	1650	3500	
Height (mm) symmetrical division of leaves	2100	2100	

\* Division in width left / right at least 1000 mm

Multi-purpose doors are supplied as standard with honeycomb infill. External doors are optionally available with mineral wool infill, track cover and hold-open locking function. Aqua multi-purpose doors come with water-resistant PU infill. They are available in steel and stainless steel.

### Single-leaf

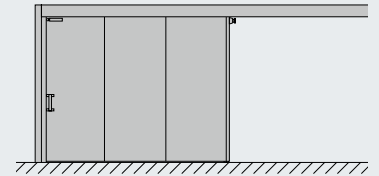

### Double-leaf

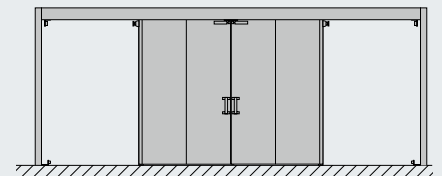

### Telescopic sliding door

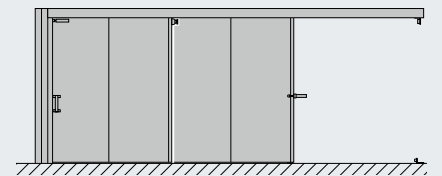

### Wicket door

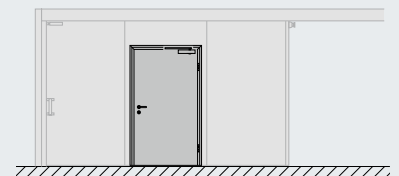

	Wicket door
<b>Standard size (standard)</b>	
Width (mm)	1000
Height (mm)	2000
<b>Special sizes</b>	
Width (mm)	625 – 1200
Height (mm)	1750 – 2000

# Wicket Doors

Version without threshold also approved for smoke-tight sliding doors



### Design features

- Rebated door construction
- Version without threshold for escape routes acc. to DIN EN 179 and EN 1125
- Version with 22 mm threshold for additional stability and for ascending floors or parking ramps, e.g. in underground garages
- With smoke protection function up to 20 m<sup>2</sup> door surface
- Up to 2 wicket doors per door leaf
- Wicket door opening in both directions, depending on the source of danger (also in opposite direction of opening)
- Optional glazing: standard size 468 × 815 mm, special size max. 500 × 1000 mm

### Wicket door monitoring via radio

- Radio transmission with magnetic contact and transmitter in door leaf
- Separate receiver incl. wall fitting
- Optional latch switching contact and electric strike (signal transmission system with concealed wiring and spiral cable at end of door leaf)

### Overhead door closer

- Standard slide rail overhead door closer HDC 35
- Optional slide rail overhead door closer TS 5000
- Optional integrated overhead door closer ITS 96

### Sports hall recessed handle // NEW

- As standard in stainless steel
- Flush-fitting track application, minimally protruding with version according to DIN EN 179
- Emergency exit lock acc. to DIN EN 179
- Approved for escape routes

### Fittings

- 3-way adjustable galvanized hinges for easy adjustment of the door
- Optionally in stainless steel or RAL colours

### Lock variants

- Mortice lock for fire-rated and smoke-tight doors in accordance with DIN 18250 (standard BKS 1206)
- Optional panic function in accordance with EN 179 and EN 1125 for wicket doors opening into the reveal

### Wicket door versions



Version without threshold for escape routes acc. to DIN EN 179 and EN 1125



Version with 22 mm threshold for additional stability and for ascending floors or parking ramps, e.g. in underground garages

### Approved variants of the wicket door

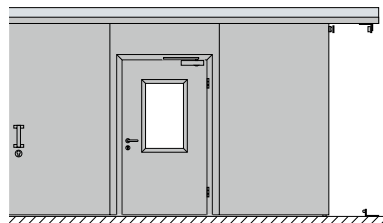

Single-leaf with wicket door

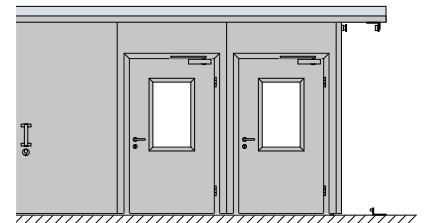

Single-leaf with two wicket doors

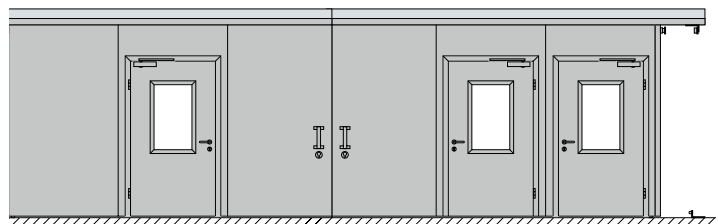

Double-leaf with three wicket doors

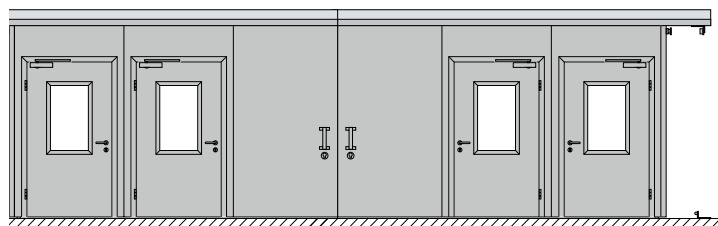

Double-leaf with four wicket doors

### Sports hall recessed handle according to DIN EN 179



# Flush-stopping sliding door

## For maximum clear passage width

EI<sub>2</sub>30

### Flush-stopping fire sliding door without guiding profile

In this exclusive solution for construction projects, the door closes flush with the wall thanks to a stainless steel fascia. The full clear passage remains available. There is no need for a guiding profile which would disturb the overall appearance.

#### Versions / functions

- T30 / EI<sub>2</sub>30 fire sliding door, flush-stopping
- Spring-loaded stainless steel guide bolt, intumescent coating and rubber double seal ensure safety
- Flush, fully bonded door sets
- Single-leaf
- Max. size 7500 x 4500 mm

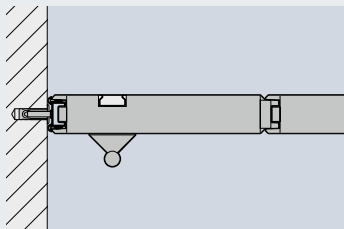

Sliding door without guiding profile

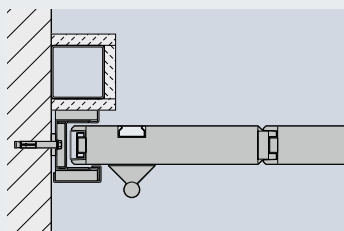

Sliding door with guiding profile



Spring-loaded stainless steel guiding bolt

# Recess and ceiling flaps

For an inconspicuous integration of the door



Recess flap with the door closed



Recess flap with the door opened



Recess flap stainless steel V2 A



Recess flap with cladding frame  
for timber embellishment

## Recess and ceiling flaps

With these solutions, sliding doors can be inconspicuously integrated in the wall and ceiling.

A vertical recess flap blends the inlet and outlet areas of the door.

The minimum width for a recess flap is 180 mm.

In the lintel area, the tracks can be horizontally blended with a ceiling flap. It is manually closed. The opening is triggered automatically through a control.

Recess and ceiling flaps are also available for telescopic sliding doors. The flaps are available galvanized, primed, coated in colour or in stainless steel V2 A, 14301. Optionally available with stainless steel cladding frame for cladding with gypsum board, timber or tiles.

# Operator solutions for sliding doors

Opening and closing during daily operation



Combination with the operators  
SupraMatic HT and ITO 400



1

Stainless steel fire sliding doors that require opening and closing several times a day can be equipped with a convenient and fast operator. The operator is maintenance-free and particularly suited for high-traffic areas.

- Quick opening and closing during daily operation
- A patented compensator release system unlocks the operator in case of fire
- Reliable closing of the fire sliding door by weights in case of fire

## 1 Operator SupraMatic HT

- Up to 800 kg weight of door leaf
- Up to 6090 mm clear passage width
- Impulse operation "Open-Close"
- Operation via hand transmitter or button
- With internal control as standard
- Optionally with external control 360 with automatic timer



2

## 2 Chain drive operator ITO 400

- Up to 2500 kg weight of door leaf
- Up to 8500 mm clear passage width
- Press-and-hold or impulse operation "Open-Close" // NEW
- Operation via hand transmitter or button
- With external control A 445 as standard
- Optionally as FU version with external control B 460 FU with soft start and soft stop



## Convenient operator solution with the optional *SupraMatic HT* and *ITO 400* operators



### Controls

#### 1 External control 360

- Optional for SupraMatic HT
- With automatic timer
- With second opening width, half-open
- With warning lights connection

#### 2 Control A 445

- As standard for ITO 400

#### 3 FU control B 460 FU

- Optional for ITO 400
- With soft start and soft stop



### Control elements

#### 1 4-button hand transmitter HS 4 BS

- Optional for SupraMatic HT

#### 2 Key switch STUP 50 / STAP 50

- Optional for SupraMatic HT and ITO 400

#### 3 Push button DT 02

- Optional for SupraMatic HT and ITO 400

#### 4 Radio internal push button FIT 1 BS

- Optional for SupraMatic HT

#### 5 Warning lights

- Optional for SupraMatic HT with external control 360
- Optional for ITO 400



### Opening aid

Automatic door opening with press-and-hold operation.

The integrated hold-open device ensures that the door leaf is secure in the open position.

The door is closed via closing weights by actuating the hand button.

The opening aid is maintenance-free and optionally available with a key switch.

It is ideal for opening large doors.

# Special equipment

## For special requirements

### Compensator

The compensator allows for free positioning of the door leaf. This means the door can be easily opened, for example only halfway, making it ideal for fire sliding doors that are operated multiple times each day. The door closes automatically via the compensator carriage and counter weight in the case of fire, with the push of a button or during a power failure. The radial damper for regulating the required timer speed (5 – 12 cm/s) is integrated in the compensator carriage.

### Lockable door leaf and wicket door

Single- and double-leaf fire sliding doors are optionally available with hook catch locks or curved bolt locks with a profile cylinder in the door leaf.

Hook catch lock / curved bolt lock

- Backset 120 mm, PC and RC
- Backset 250 mm, profile cylinder; for example, for recess flaps

For simple retrofitting of single- and double-leaf doors, a retrofit lock is available.

### Anti-collision bollard and collision guard

Available as optional crash protection for galvanized or painted RAL 1021 (Rape yellow) sliding doors.

**Anti-collision bollard (W x H)**

- 1000 x 114 mm

**Collision guard (W x H)**

- 1250 x 400 mm, type 1
- 625 x 400 mm, type 2



1



2

# Hold-open devices

Conveniently opened during daytime operation  
and safely closed in case of fire



1



2

## FSA-Basis hold-open device control centre 1

The control centre combines the power supply, warning signals, fire detector evaluation, manual release button and reset device in a compact housing. In addition, status and alarm states are signaled via LED lamps or via an acoustic signal. Furthermore, fire detectors, magnets, recess flaps and fire alarm systems can be easily connected.

## FSA-Plus hold-open device control centre 2

For reliable operation, even in the event of power failures, the FSA-Plus version has battery backup. It is also particularly suitable for the controlled use of ceiling and recess flaps in combination with sliding doors. The functional scope corresponds to that of the FSA-Basis hold-open device control centre.



3

## Visual / acoustic alarm system FSA-OAW 3

The extension for the FSA-Basis and FSA-Plus hold-open device control centres in conjunction with a Hörmann flashing warning light provides a visual and acoustic warning during door travel.



4

## Visual fire detector H-RM-4070 4

The visual smoke detector works according to the familiar scattered light principle and thus detects the smoke development of many different fires. The sensor chamber contains a visual sensor capable of measuring both reflected and normal scattered light. Algorithms make alarm activation of the detector very reliable.



5

## Thermal detector H-TM-4070 5

The thermal detector has an open housing that allows the ambient air to circulate freely around the thermistor. The air temperature is thereby measured every 2 seconds. A microprocessor stores the temperature measurement data and compares it to the preset limits to determine if a preset maximum value – the alarm threshold – has been reached.

# Hinged garage doors DFT FST

Single-leaf up to 4000 mm x 4000 mm



**MZ** Multi-purpose  
Single-leaf

**EI<sub>2</sub>30** Fire-retarding  
Single-leaf



**Further Information**  
• Surface finishes / colours page 14

**The ideal solution when fitting of sliding doors is not possible.**

Door type	Single-leaf
<b>MZ multi-purpose</b>	
Width (mm)	1625 – 4000
Height (mm)	2000 – 4000
<b>EI<sub>2</sub>30 fire-retarding</b>	
Width (mm)	1625 – 4000
Height (mm)	2000 – 4000

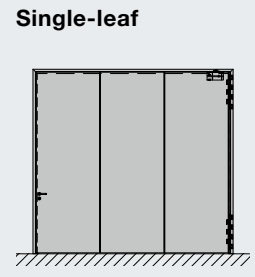

Flush, fully bonded groove / spring element with a door leaf thickness of 72 mm



Block frame 140 / 75 mm, 3-part with all-round lining groove on three sides



2-way adjustable, galvanized hinges



90° open position with magnet



Mortice lock with lever/knob BKS 1206 with stainless steel lock cover and lock plate



Overhead door closer TS 4000 for fire-retarding version

# Horizontal views

## Single-leaf, double-leaf and telescopic versions

### Single-leaf version

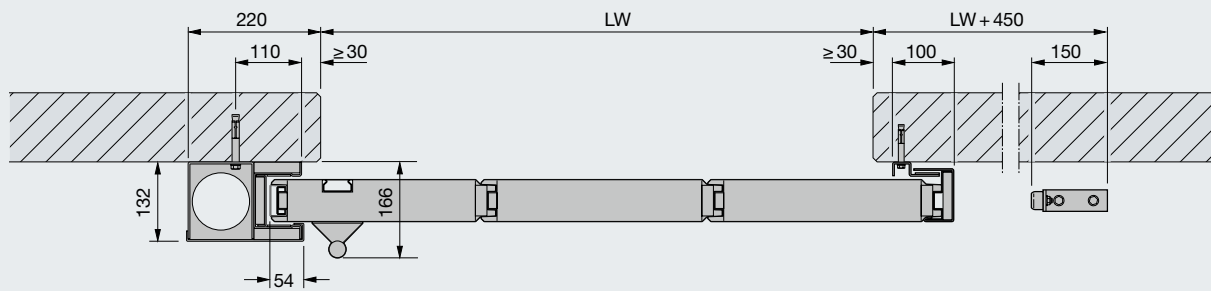

### Double-leaf version

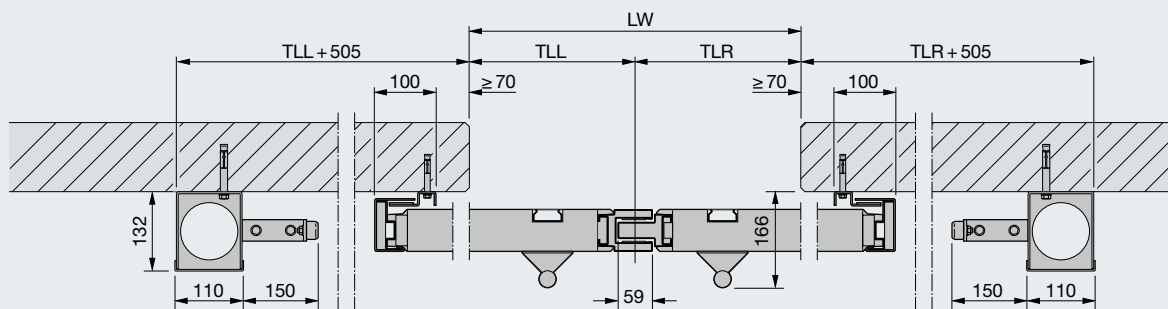

### Double telescopic version

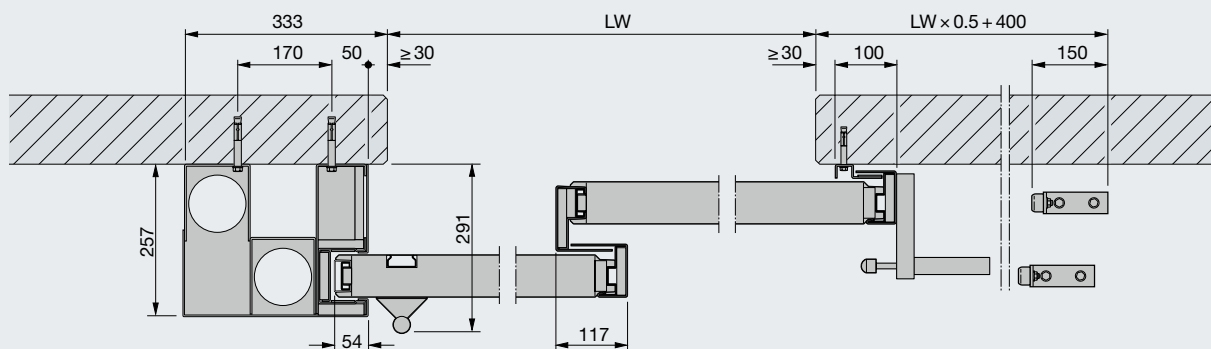

# Vertical views

## Single-leaf, double-leaf and telescopic versions

### Single- and double-leaf version

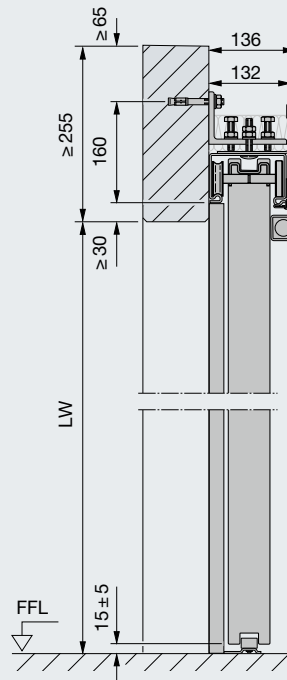

### Explanations

- LW Structural opening
- TLL Division left
- TLR Division right

The illustrated door views show versions with standard guiding, wall fitting, and without smoke protection function.

### Notice

The construction tolerances to be complied with depend on the requirements provided in the official approval of the fire and smoke-tight sliding doors.

### Double telescopic version

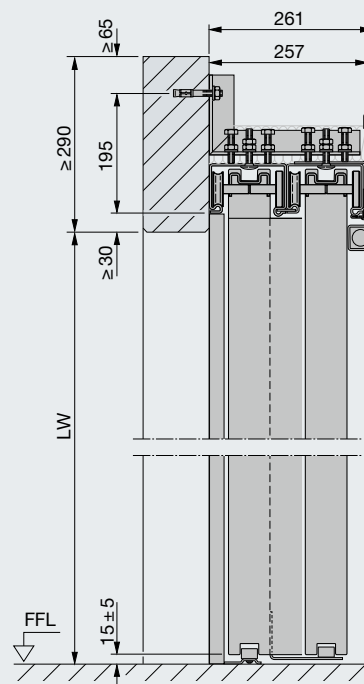

# Sliding doors with wicket door

Door views

Vertical views

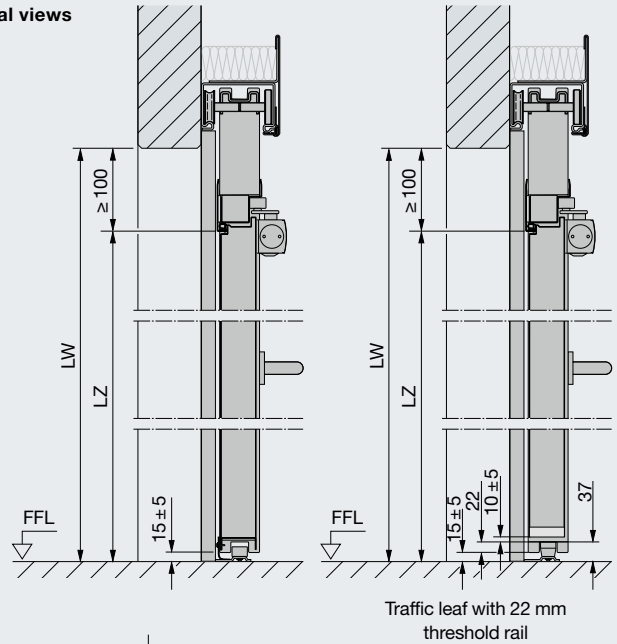
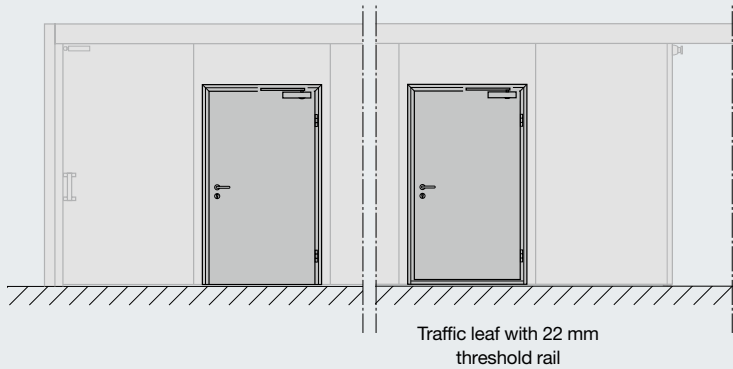

Horizontal view

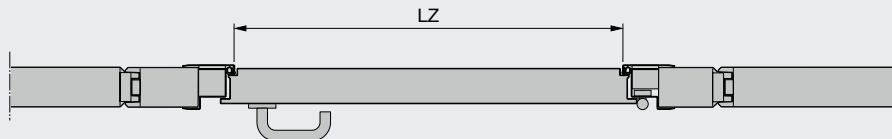

Single-leaf fire sliding door

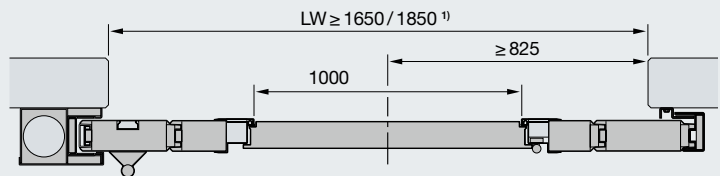

Double-leaf fire sliding door, asymmetrical division

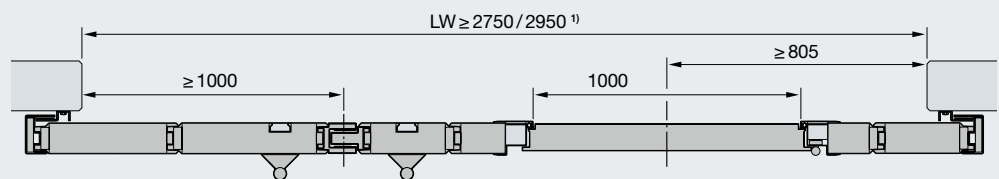

Double-leaf fire sliding door, symmetrical division

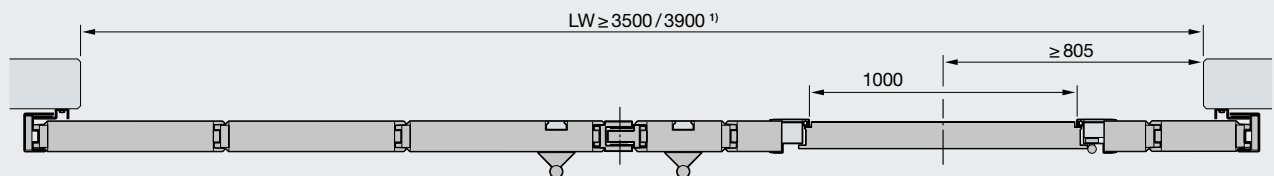

Double telescopic door

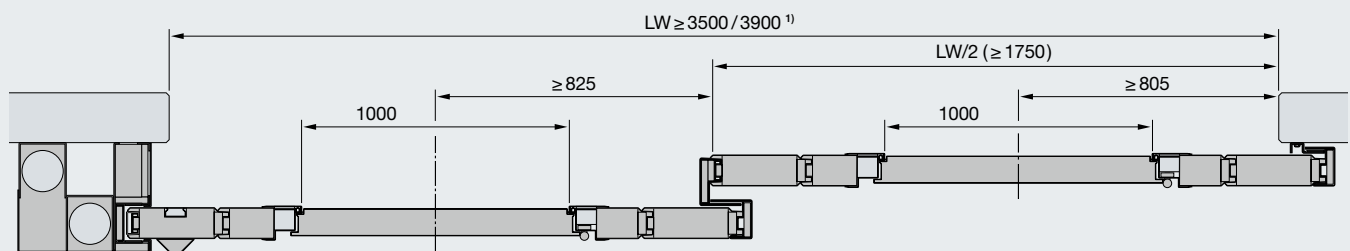

Handle part  
T30/EI<sub>2</sub>,30, T90/EI<sub>2</sub>,90 available with wicket door

Wall section  
T30/EI<sub>2</sub>,30 available with wicket door



# Recess and ceiling flaps

## Recess flaps for the wall area

### Horizontal view, single- and double-leaf sliding door

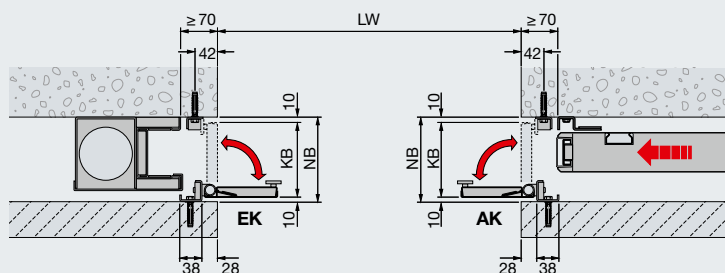

## Recess flaps for on-site infill

### Horizontal view, single- and double-leaf sliding door

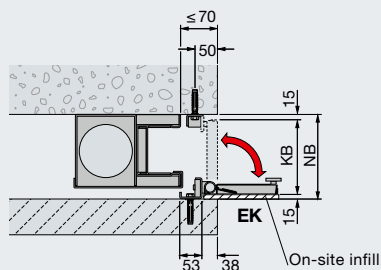

## Ceiling flaps for the lintel area

### Vertical view, single- and double-leaf sliding door

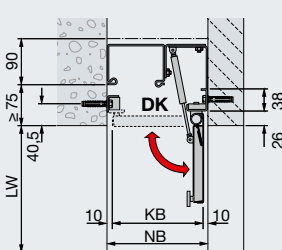

## Recess flaps for the wall area

### Horizontal view, telescopic sliding door

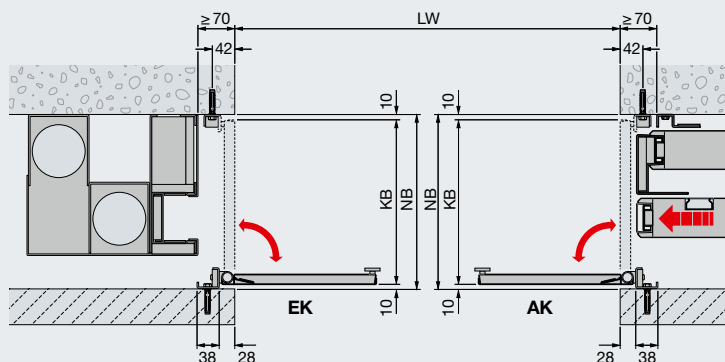

## Ceiling flaps for the lintel area

### Vertical view, telescopic sliding door

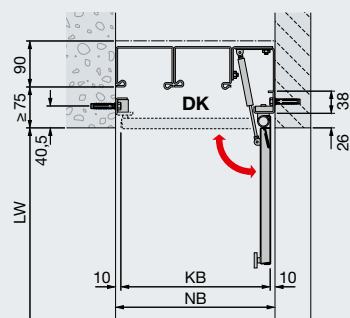

## Explanations

- LW Structural opening
- LZ Clear frame dimension
- EK Inlet flap
- AK Outlet flap
- DK Ceiling flap
- KB Flap width
- NB Recess width

The illustrated door views show versions with standard guiding, wall fitting, and without smoke protection function.

### Notice

For a recess width  $\leq 340$  mm, a door leaf with recessed lever handle on both sides (vertically offset) is required. For doors with fitted traffic leaf, recessed lever handles on both sides and an integrated overhead door closer Dorma ITS 96 are required. Retrofitting of recess flaps in existing door systems is not possible, due to the required larger door overlap.

The construction tolerances to be complied with depend on the requirements provided in the official approval of the fire and smoke-tight sliding doors.

### Cladded recess flaps

Cladding on a stainless steel cladding frame with timber, gypsum and tiles is possible up to a thickness of 10 mm. Max. cladding weight: 25 kg/m<sup>2</sup>

Space requirements and edge gaps deviate from the values for the standard flaps.

<sup>1)</sup> Wicket doors with a clear passage width > 1000 mm

# Technical manual

## Brickwork walls

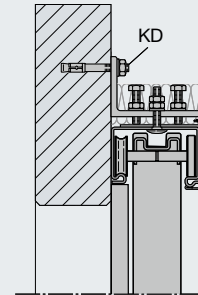
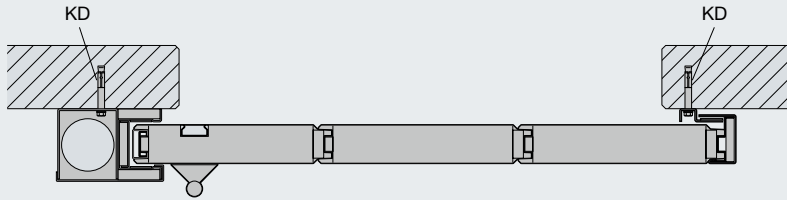

## Concrete walls

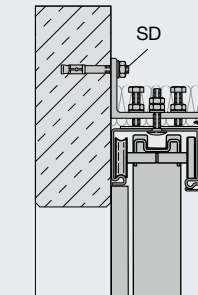
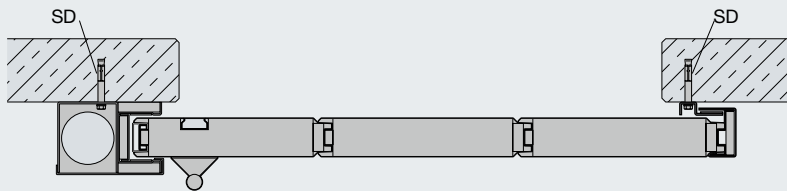

## Gas concrete walls

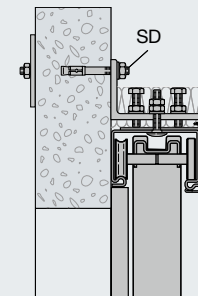
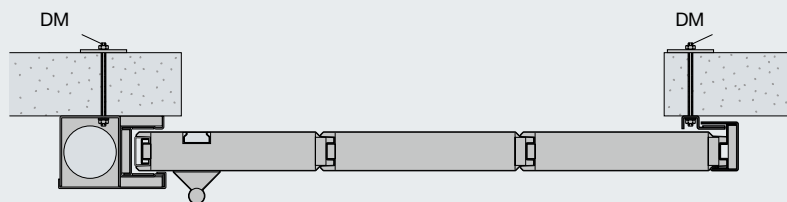

Only in combination with a steel concrete lintel according to the static proof.  
The lintel must extend beyond the door opening area in line with the door track length.

## Cladded steel components

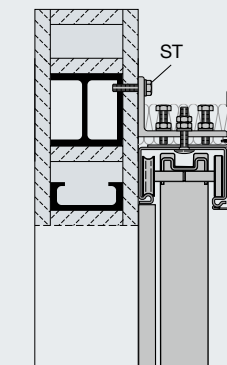
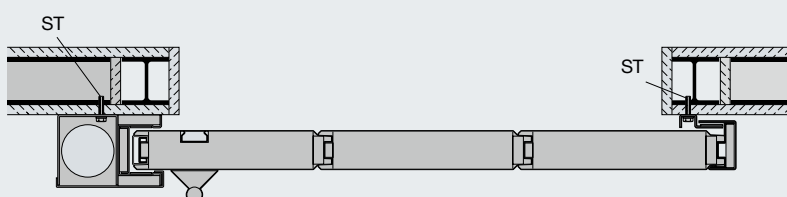

Cladded steel supports and / or girders, minimum fire resistance class F90,  
short designation F90-A according to DIN 4102-4.

Wall fitting to the lintel

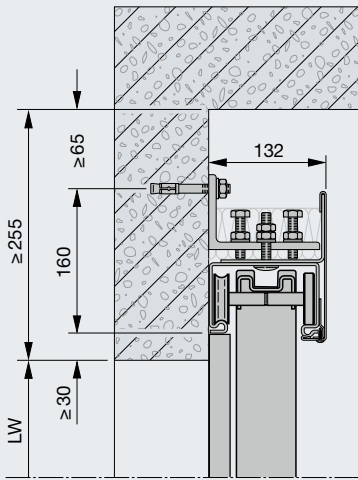

Fitting to the wall

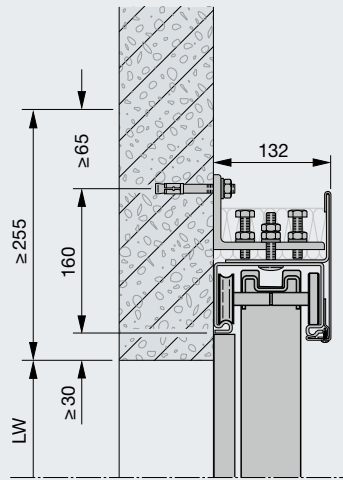

Direct fitting to the ceiling

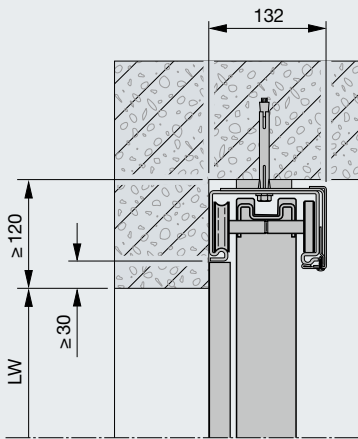

Direct fitting to the ceiling with false lintel

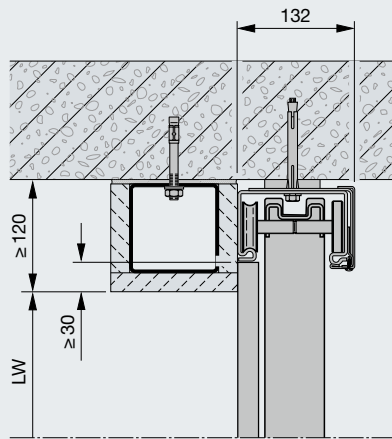

Suspended ceiling fitting (only for parking area)

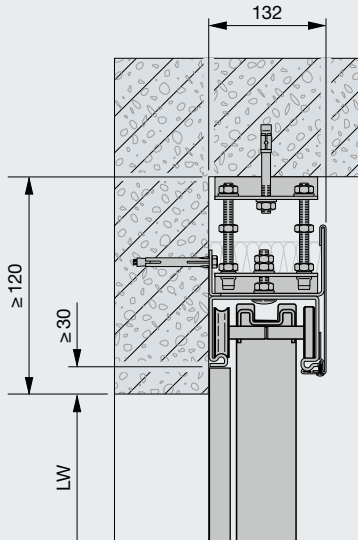

**Explanations**

- LW Structural opening
- DM Through-bolt fixing with threaded rod M10 nut, pane and counterplate 80 x 80 x 5 mm
- SD Steel expansion dowels Ø 10 (M6) x ≥ 80
- ST Steel screw M8
- KD Plastic dowels 10 x 120 mm

**Minimum wall thicknesses**

Brickwork walls according to DIN 1053-1<sup>2</sup>, strength class min. 12, normal mortar ≥ II: 175 mm  
 Concrete walls according to DIN 1045-1, strength class min. C 12/15: 140 mm  
 Walls made of gas concrete, stone slabs or precision blocks according to DIN 4165<sup>4</sup> part 3, strength class 4: 240 mm  
 Walls made of reinforced gas concrete slabs, laid flat or standing, provided general official approval is available; strength class 4.4: 200 mm

**Notice**

The construction tolerances to be complied with depend on the requirements provided in the official approval of the fire and smoke-tight sliding doors.

# Flush-stopping sliding door

## Without guiding profile

Flush-stopping single-leaf sliding door

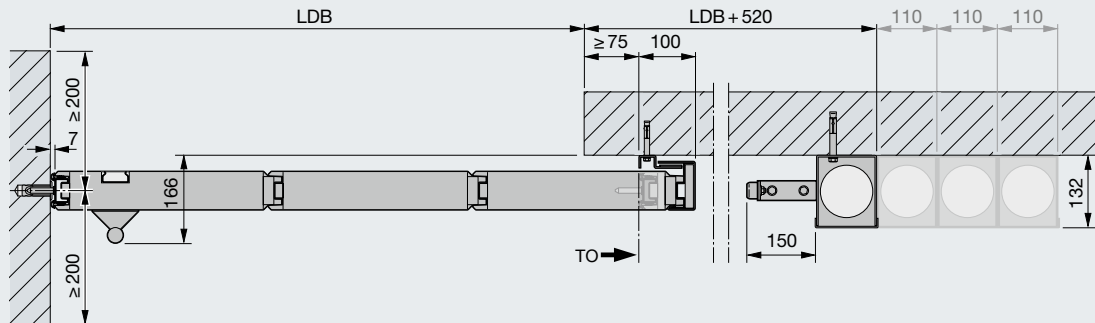

Flush-stopping telescopic sliding door

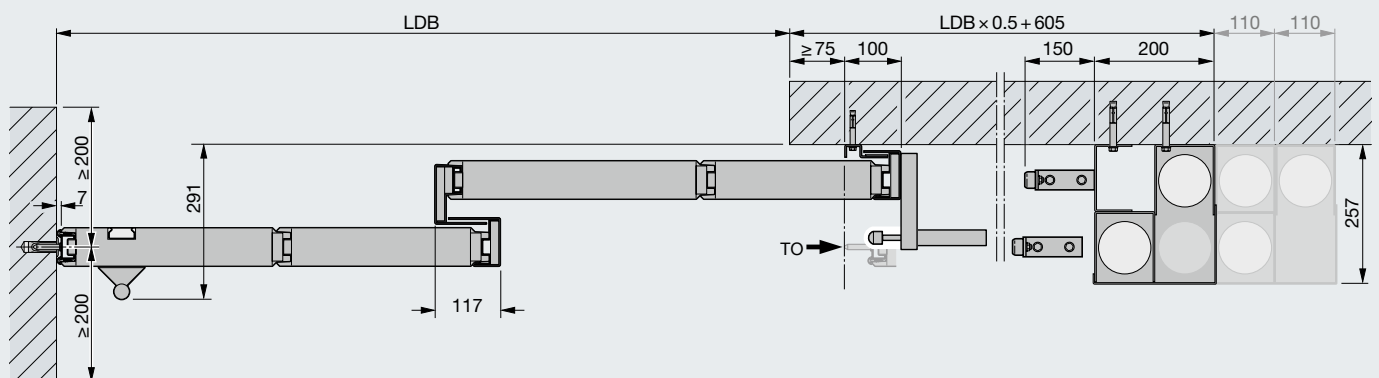

# Technical data

## Hinged garage doors DFT FST

Horizontal view

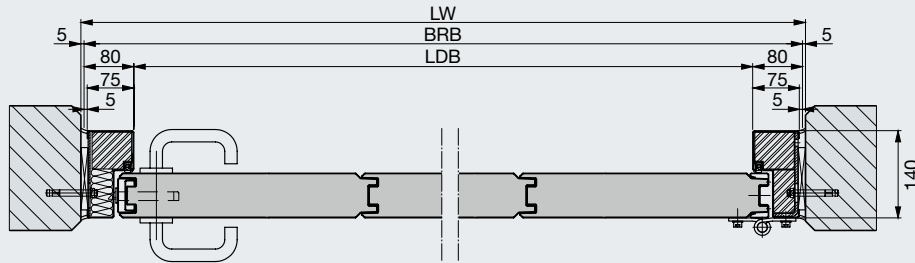

### Explanations

- LW Structural opening
- BRB Nominal size width
- LDB Clear passage width
- BRH Nominal size height
- LDH Clear passage height

Vertical view

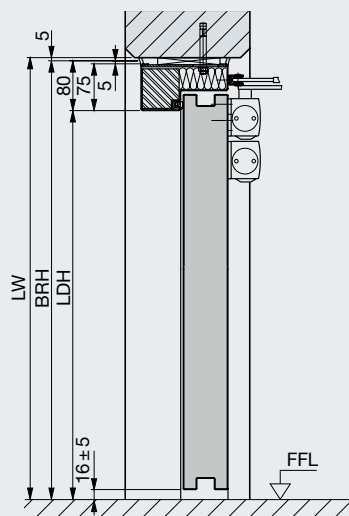

90° open position

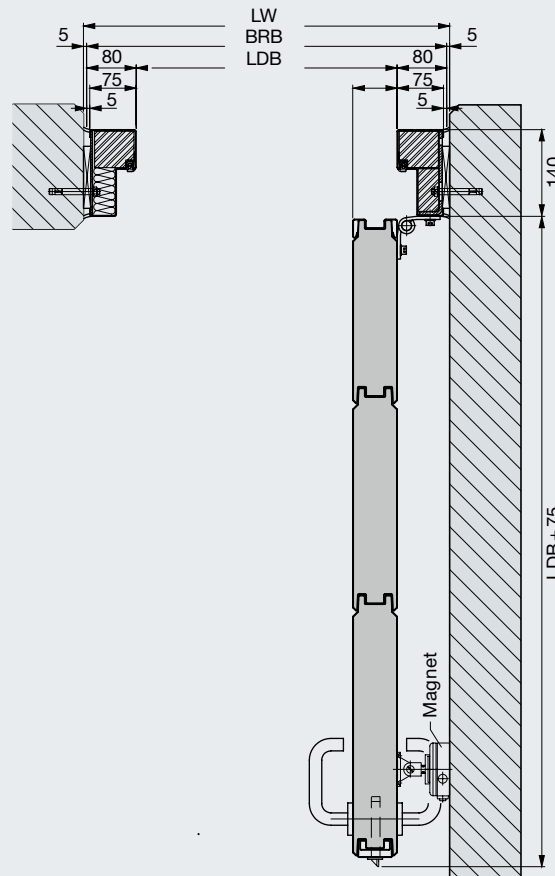

# Hörmann Product Range

Everything from a single source for your construction project





**Quick service with testing, maintenance and repairs**

Our extensive service network means that we are always nearby and at your service around the clock.

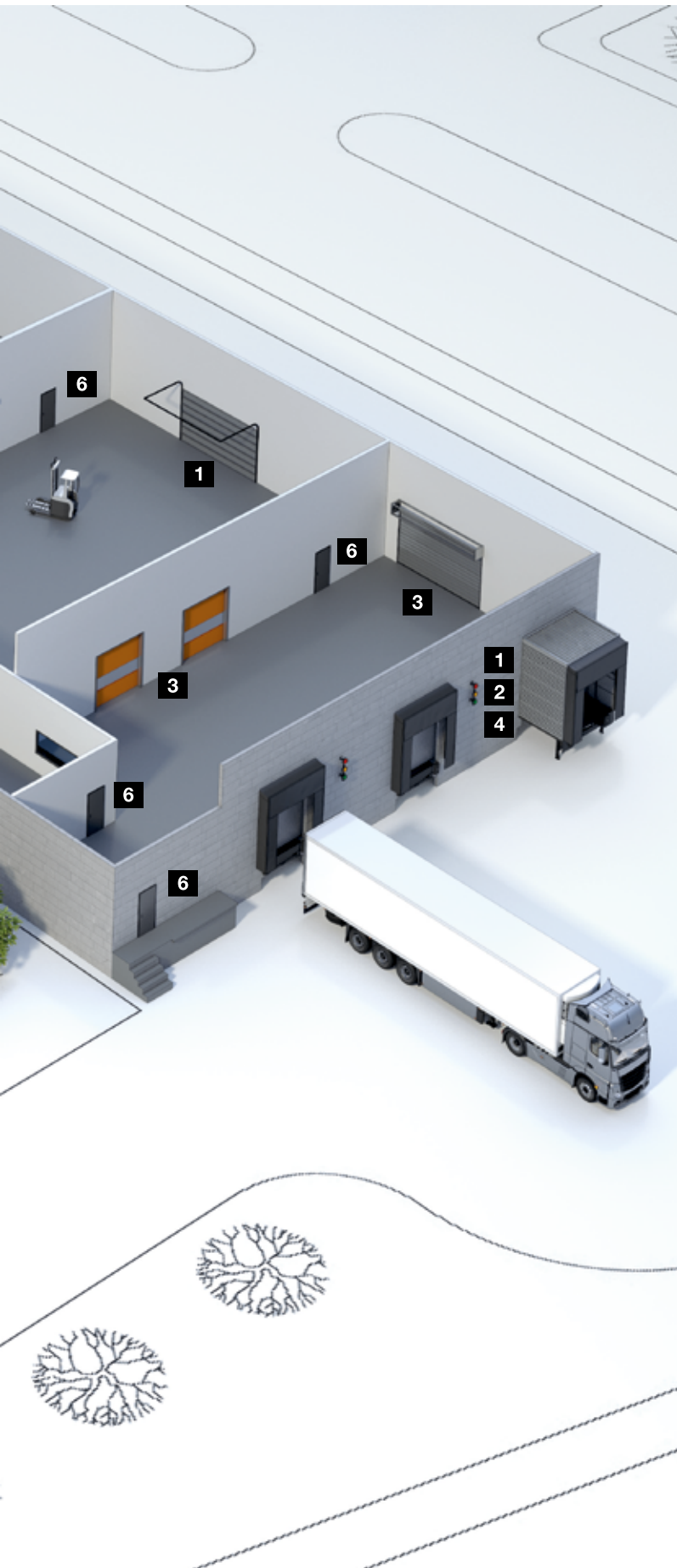

**Sectional doors**



**Rolling shutters and rolling grilles**



**High-speed doors**



**Loading technology**



**Steel and stainless steel sliding doors**



**Steel and stainless steel construction project doors**



**Steel frames with high-quality timber function doors from Schörghuber**



**Tubular frame construction project doors**



**Automatic sliding doors**



**Visibility window**



**Collective garage doors**



**Bollards and road blockers**



**Barrier and pay station systems**

## Hörmann: Quality without Compromise



Hörmann KG Amshausen, Germany



Hörmann KG Antriebstechnik, Germany



Hörmann KG Brandis, Germany



Hörmann KG Brockhagen, Germany



Hörmann KG Dissen, Germany



Hörmann KG Eckelhausen, Germany



Hörmann KG Freisen, Germany



Hörmann KG Ichttershausen, Germany



Hörmann KG Werne, Germany



Hörmann Alkmaar B.V., Netherlands



Hörmann Legnica Sp. z o.o., Poland



Hörmann Beijing, China



Hörmann Tianjin, China



Hörmann LLC, Montgomery IL, USA



Hörmann Flexon LLC, Burgettstown PA, USA



Shakti Hörmann Pvt. Ltd., India

Hörmann is the only manufacturer worldwide that offers you a complete range of all major building products from one source. We manufacture in highly-specialised factories using the latest production technologies. The close-meshed network of sales and service companies throughout Europe, and activities in the USA and Asia, make Hörmann your strong partner for first-class building products, offering “Quality without Compromise”.

**GARAGE DOORS**  
**OPERATORS**  
**INDUSTRIAL DOORS**  
**LOADING EQUIPMENT**  
**HINGED DOORS**  
**DOOR FRAMES**

**HÖRMANN**