

# XPANDA TRACKLESS BARRIER SYSTEM



EMAIL: [ENQUIRIES@SAMSONDOORS.CO.UK](mailto:ENQUIRIES@SAMSONDOORS.CO.UK)  
TELEPHONE: (01933) 448850  
MON - FRI 8:30AM - 5:30PM



## MOBILE TRACKLESS BARRIER SYSTEMS

The Xpanda Mobile Trackless barrier system is a simple, but effective way of restricting access / cordoning off areas - such as quarantine areas / Liquor stores / Factory entrances / exits etc, yet still allowing visual sight beyond the barrier and free flow of air in heated areas or on hot weather days.

Types of application :-

SINGLE SASH system

BI PARTING SASH system

FREE FLOATING SASH system

By using both Xpanda Saftidor sashes and Type B & D trolley units. Barrier systems can be erected in situ to create either:-

Single Sash opening (fixed to one side & locking at the leading edge) - Fig 1.1

Bi Parting opening (fixed to both sides of opening and locking in the centre) - Fig 1.2

Free Floating Barrier (can be wheeled from site to site or stored away after use) - Fig 1.3

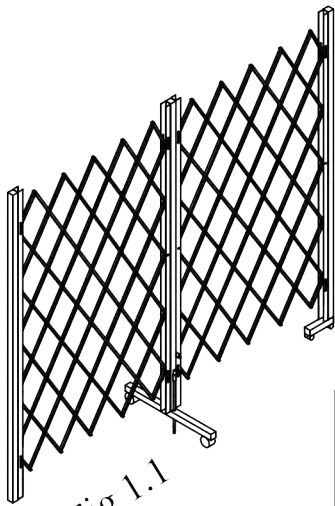

Fig 1.1

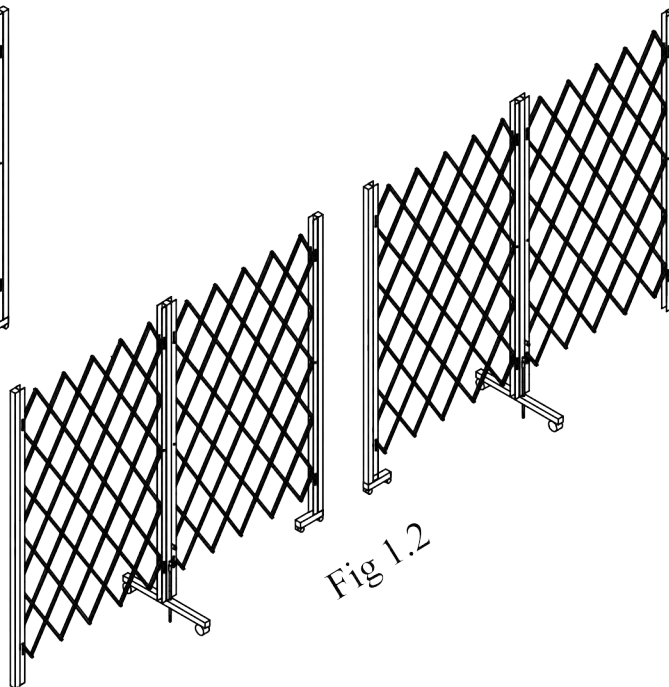

Fig 1.2

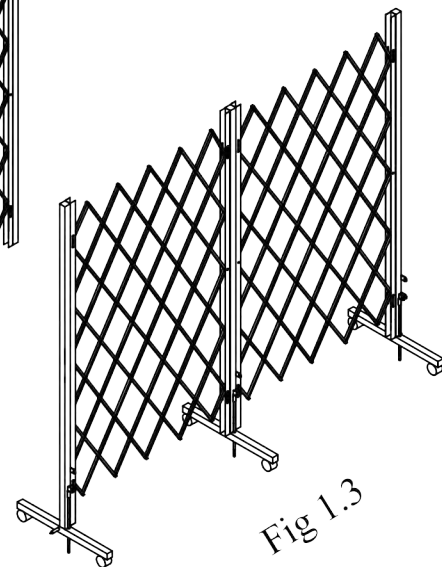

Fig 1.3

NOTE:- Widths are unlimited, but you should bear in mind the weight of the units and ensure that the people using the systems are capable of manouvering / pulling them with relative ease.



## MOBILE TRACKLESS BARRIER SYSTEMS

EG: A barrier system stretching over a width of 10 metres+ should be made up of small sections which can be easily manhandled into position and locked down by use of the drop bolts attached to the Type B trolleys OR locked together using the L205B slamlock if required OR by customers own padlock and chain system.

### 2. FITTING OF TRACKLESS BARRIER SYSTEMS

1. Mark channels of Saftidor top, bottom and centre, making sure that you can get access to bolts / fixings between diamonds on Saftidor in centre. Drill 6mm holes (or appropriate size hole for type of fixing being used).
2. Mark upright of trolley to match holes in the Saftidor channels and drill 6mm holes (or appropriate size holes for type of fixing being used). - Fig 2.1
3. Fix channels to 38mm post of Trolley top, centre and bottom, with bolts and nuts / self tapping screws being used.

**NOTE** - This is the recommended method of fixing, however pop rivets can also be used if preferred.

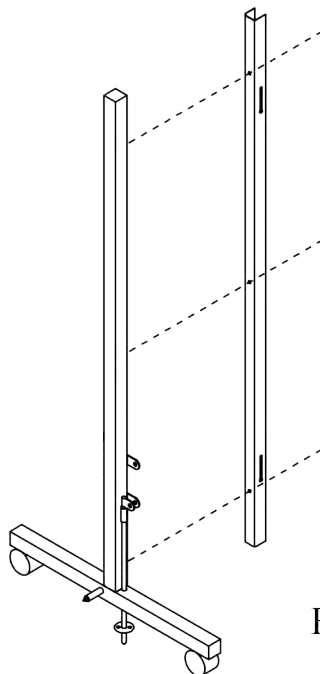

Fig - 2.1

## 2.1 Fixing of Trolley System to Wall with hinges supplied with Saftidors.

2.1.1 Where a Trolley system is being fixed to either one wall or 2 walls in the case of either a single or Bi-parting application, the S4 Butt hinges supplied with the Saftidor sash can be fixed directly to the channel of the Saftidor and then onto the existing wall. (Ensure that when fitting the hinges, the trolley system can swing in the correct direction required!). - Fig 2.1.1

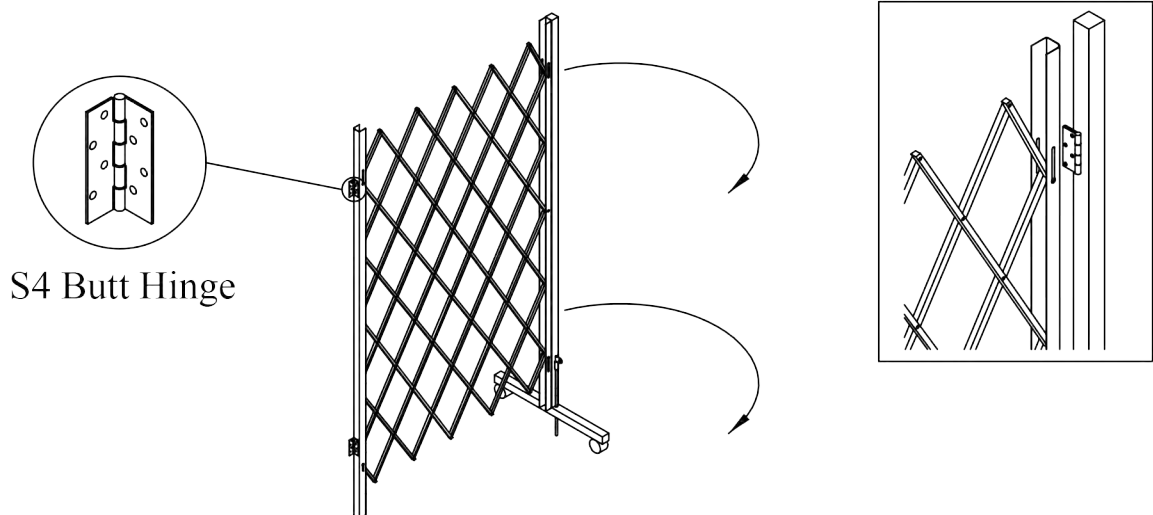

Fig 2.1.1

NOTE:- Hinges do not necessarily have to be fitted between the Saftidor sashes and Type B trolleys, but if in a long run of barrier system there is a need for a Pedestrian opening, this can be achieved by using the hinges between saftidor and Trolleys.

## 2.2 Fitting of Shootbolts (attached to Type B trolleys) into floor.

2.2.1 Once the trolley system is in place, mark the shootbolt positions on the floor and then drill out the holes on the floor, in which the drop bolt will locate. Ensure that a correct depth is achieved to ensure that when the drop bolt is located into the floor - the padlock bracket at the top of the shoot bolt meets the padlock bracket set at the bottom of the trolley post, so that a padlock can be located correctly (if required). - Fig 2.2.1

2.2.2 Sprung loaded dust covers for fitting into floors/surfaces, can be supplied for use with the dropbolts, if required. - Fig 2.2.2

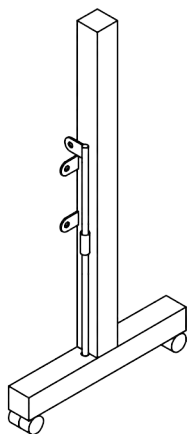

TYPE 'B'

Fig 2.2.1

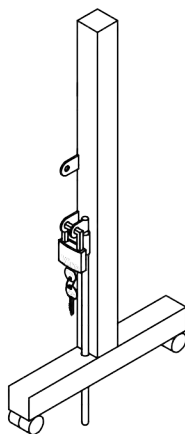

TYPE 'B'

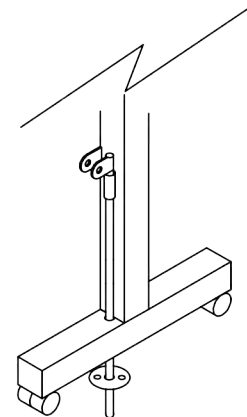

Fig 2.2.2

## 2.3 Fixing of Trackless Barrier systems

ENSURE that when fitting the Saftidor sashes to the Type B trolleys, they are not set so low that they will catch on the floor when being opened up or moved around. At the same time don't set the sashes too high up on the trolleys that they will hinder the trolley system when moving (in particular FREE FLOATING SYSTEMS) through doorways and low openings etc.

PLEASE NOTE - Fixings are not supplied with the barrier system(s).

The recommended fixings would be 6mm bolt and nuts / self tapping screws or pop rivets if preferred. - Fig 2.3.1

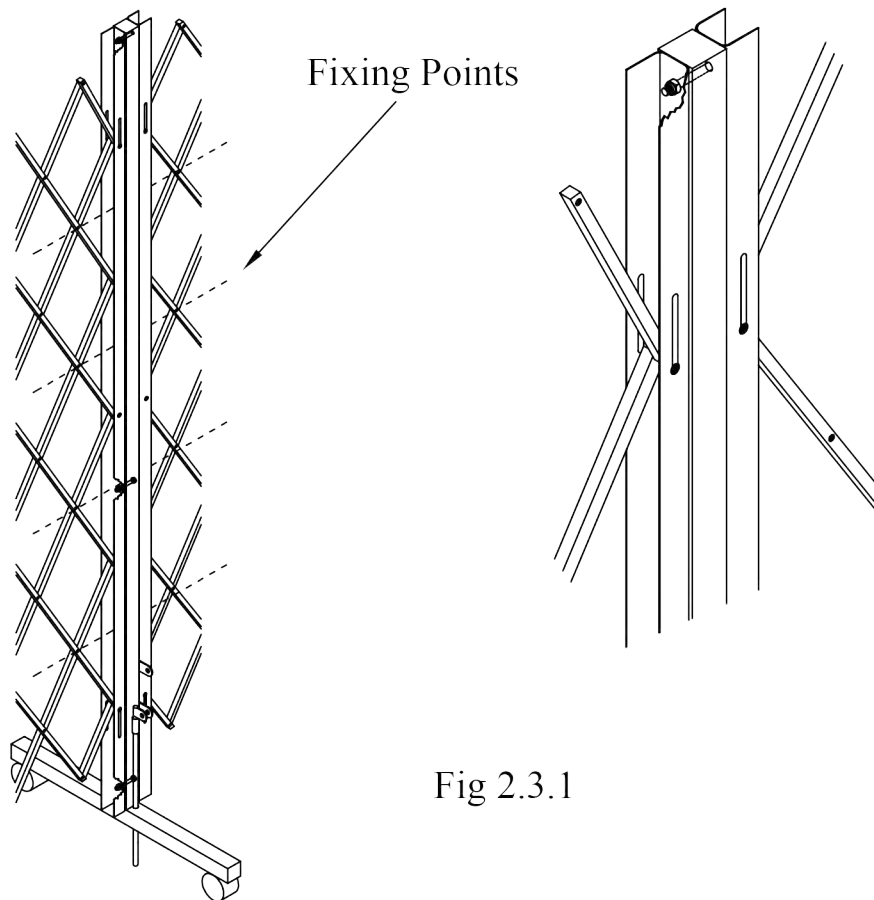

Fig 2.3.1

### 3. LOCKS

As well as the ability to use the fixed Drop Bolt on the Type B trolleys to lock the systems down into the floor (secured by padlocks - not supplied). An L205B key operated Slamlocks c/w lock keeps can be supplied to lock off Single / Bi parting or Free floating systems where required.

As notated above - Access doorways can be created in long runs of barrier systems, by using the S4 Butt hinges supplied with each Saftidor & again an L205B Slamlock can be used on these doorways (entrance / exit) points.

MOBILE TRACKLESS  
BARRIER SYSTEMS

# Single Sash System using X3 Saftidors + Type B Trolleys

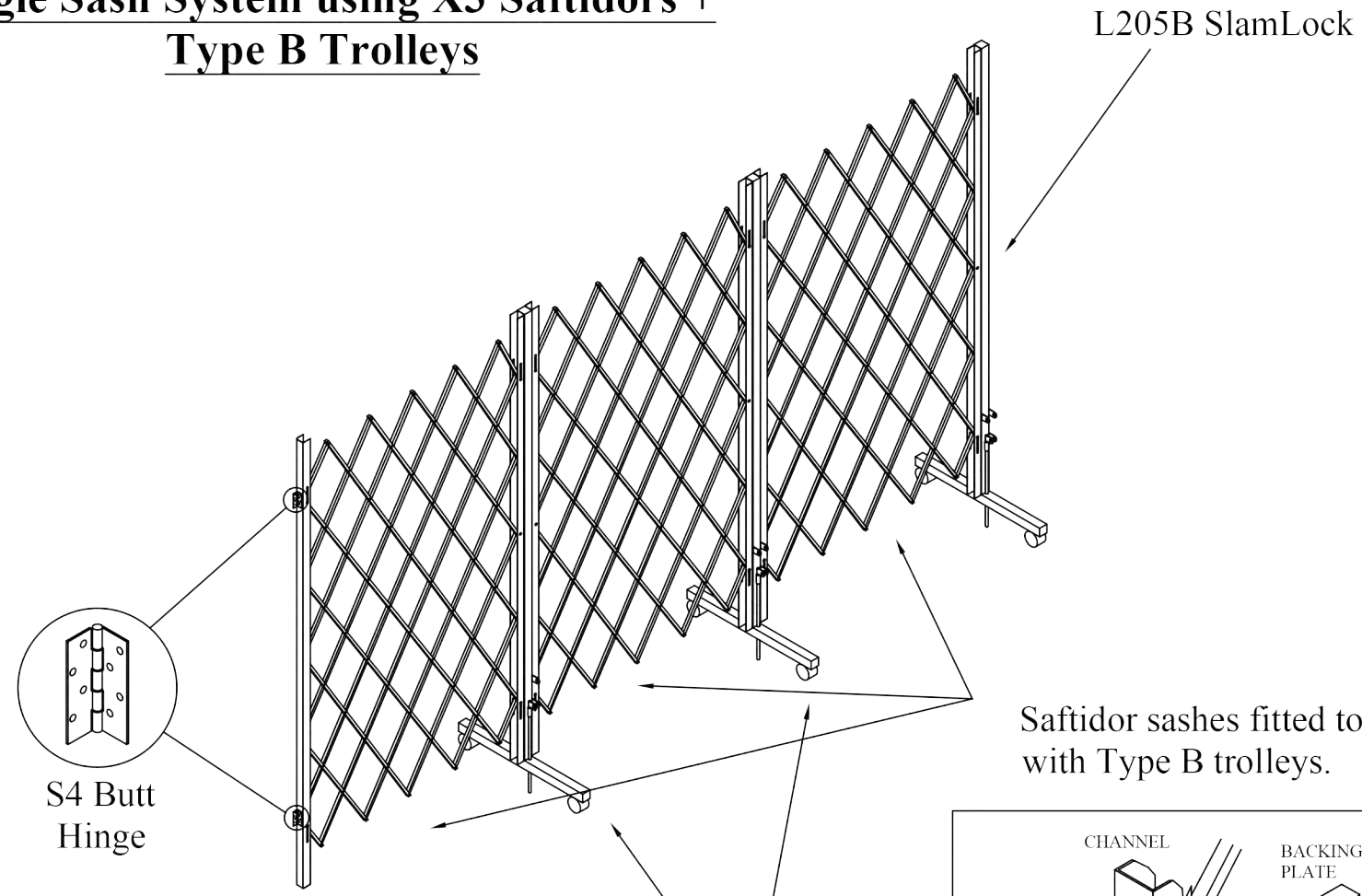

L205B SlamLock

S4 Butt  
Hinge

Saftidor sashes fitted to side posts  
with Type B trolleys.

Type B  
Trolley's  
c/w Dropbolt

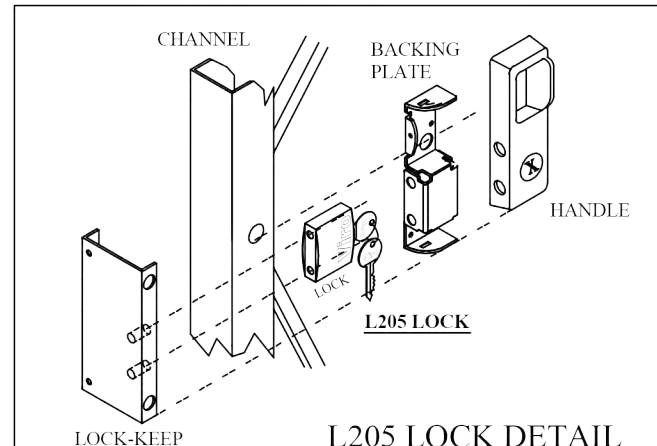

LOCK-KEEP

L205 LOCK DETAIL

10/2018



MOBILE TRACKLESS  
BARRIER SYSTEMS



# Bi Parting System using X4 Saftidors + Type B Trolleys

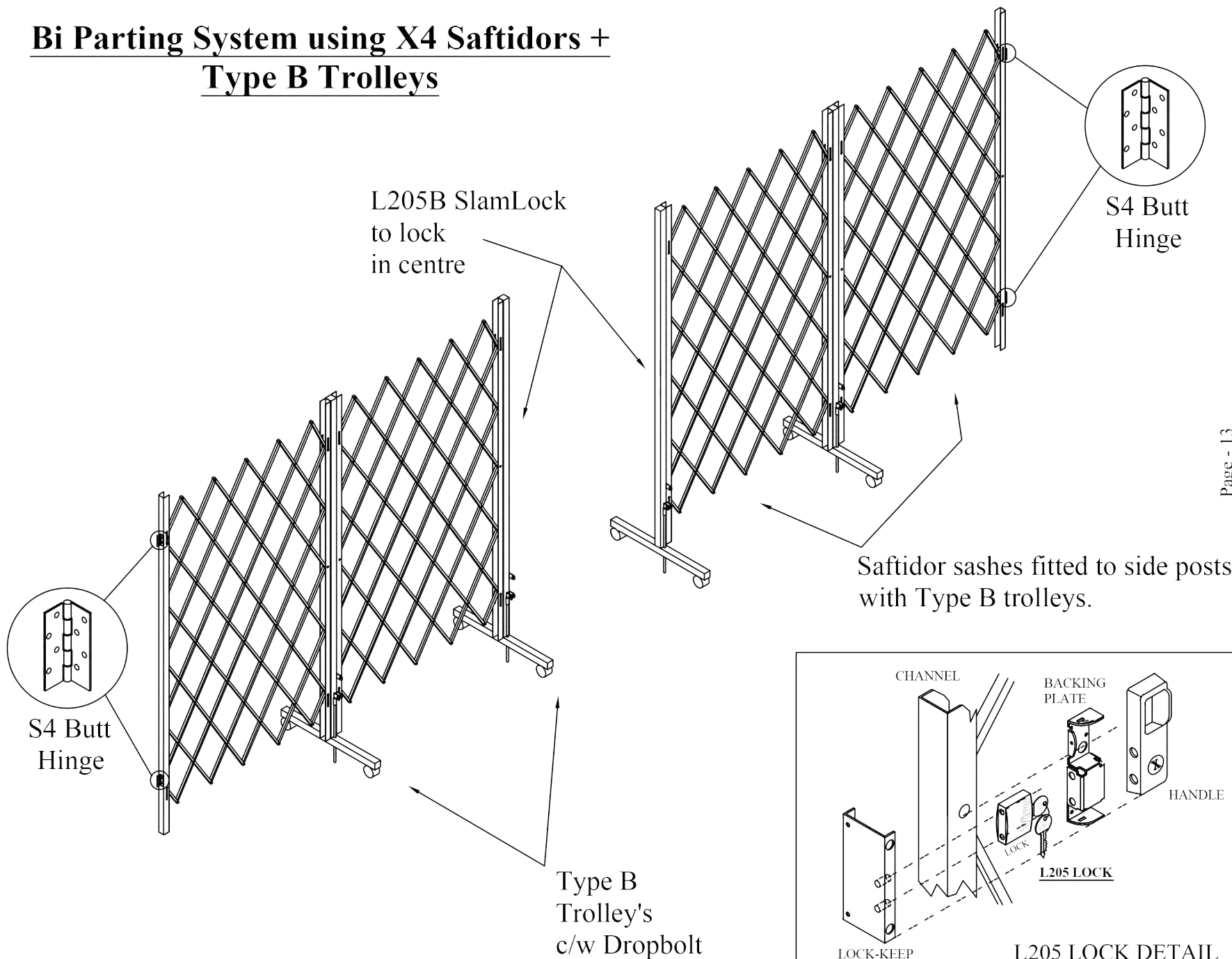



# Xpanda Barrier System

## Single

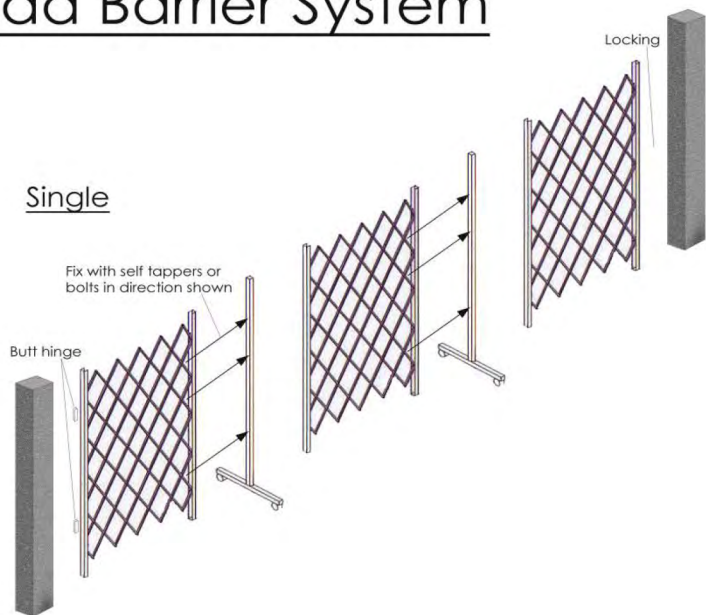

## Bi-parting

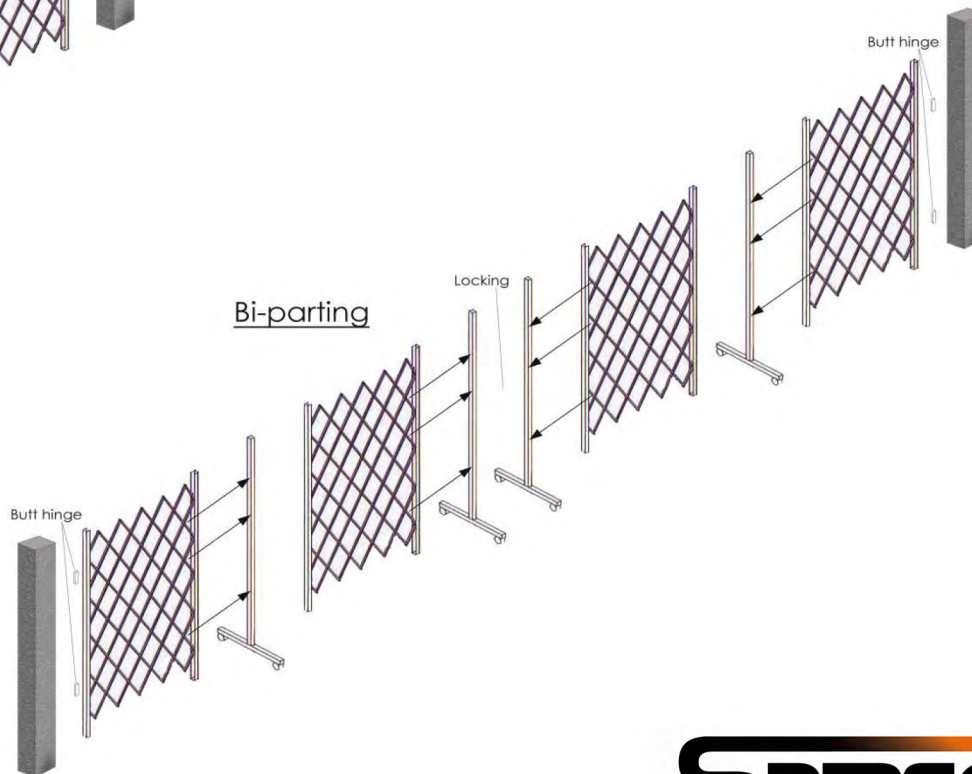

# Samson



**6-8 MEADOW CLOSE  
 ISE VALLEY INDUSTRIAL ESTATE  
 FINEDON ROAD  
 WELLINGBOROUGH  
 NN8 4BH**

**EMAIL: ENQUIRIES@SAMSONDOORS.CO.UK  
 TELEPHONE: (01933) 448850  
 MON - FRI 8:30AM - 5:30PM**

