



SeceuroGlide | Classic
Roller Garage Doors



SeceuroGlide | Excel
Roller Garage Doors

SeceuroGlide Classic & SeceuroGlide Excel Installation Instructions

Always check on delivery that the order details are correct and the door is undamaged, especially **before removing any existing doors**.

Sequence of Installation & Contents

01. Pre-Installation and Component Check
02. Installation Options and Criteria for Compliance with LPS 1175
03. Prepare the Opening
04. Prepare the Guide Rails
05. Fit End Plates, Axle Assembly, Guides (& optional fascia)
06. Fitting Emergency Overrides
07. Install the Curtain in the Guides, Attach to Axle & Fit Stops
08. Curtain Locking & Setting Motor Limit Switches
09. Curtain Adjustment (reducing height/making repairs)
10. Installation of Box Supports
11. Commissioning
12. Technical Assistance

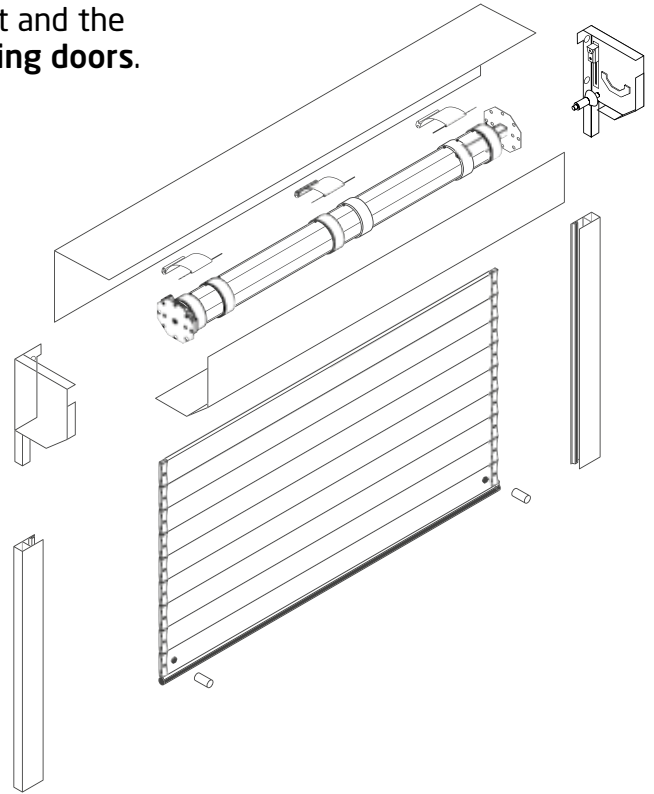

01. PRE-INSTALLATION AND COMPONENT CHECK

Check:

- i. Delivery note
- ii. Order sheet
- iii. Door dimensions / colour
- iv. Opening dimensions / clearances
- v. Components
- vi. Check for any damage to the guide rails or the outside roll of the curtain

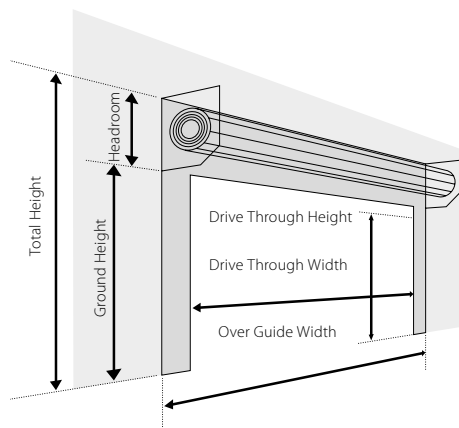

Do not proceed further with the installation unless you are sure that the door is the correct size, and all components are present.

WIDTHS

Order Width = Over Guide Width

Drive Through Width

Over Guide Width less 150mm for 75mm guides
Over Guide Width less 180mm for 90mm guides

HEIGHTS

Order Height = Guide Height

Total Height = Guide Height + End Plate

Headroom/End Plate

up to 2.5m Guide Height = 300mm
up to 3.5m Guide Height = 350mm

Drive Through Height

Guide Height less 55mm

ELECTRIC ROLLER GARAGE DOOR COMPONENTS

- 01A. Optional 90 Degree Fascia
- 01B. Optional 45 Degree Lid
- 02. Motor (fitted into axle)
- 03. 102mm Round Axle
- 04. Locking Collars (fitted to axle 6 no. up to 2.5m, 8 no. up to 3.5m
10 no. over 3.5m)
- 05. Dummy End or Spring
- 06. 6 X no. 8 X 3/8 Pan Head Screws *
(for securing octagonal fixing plates
In mounting bracket, see component 7)
- 07. Dummy End Octagonal Fixing Plate
(secured to shaft by split pin – see component 29)
- 08. Motor Octagonal Fixing Plate (bolted to motor)
- 09. Attachment/Locking Arm (1 no. L/H 1 no. R/H complete with
locking bolt and lock nut, 1 – 3 no. intermediate)
- 10. R/H End Plate
- 11. L/H End Plate
- 12. Guide Roller (fitted to end plates with star clinch lock washer)
- 13. Mounting Bracket (fitted to end plates)
- 14. Guide Rails
- 15. Brush Insert (Fitted To Guides)
- 16. Curtain
- 17. Top Slat (fitted to door curtain)
- 18. Polyester Webbing Strip (fitted to curtain)
- 19. 8 X 1/2 Flange Head Self Tapping Screw (securing webbing to curtain)
- 20. Bottom Slat (fitted to curtain)
- 21. Rubber Seal (fitted to bottom slat)
- 22. Rigid Override Eye (inc. Allen cap screw & washer) or Drop Eye
Joint (if 350mm end plates are required) *
- 23. Crank Handle
- 24. Stop Blocks * (for fitting to bottom slat)
- 25. 2 No. M6 Nuts (inserted in bottom slat for securing stop blocks)
- 26. 2 No. M6 X 30 Bolts * (for fixing stop blocks)
- 27A. 7 No. 4.8mm X 9.3mm X 12mm Pop Rivets
* (for securing axle collars)
- 27B. 3 No. 8 X 1/2 Flange Head Self Tapping Screws
* (for securing webbing strips to curtain)
- 28. Crank Handle Clip *
- 29. 1 X 60mm Split Pin (to secure the octagonal fixing plate to the dummy
end/ spring shaft)
- 30. 3 X Cable Ties * (for securing motor cable to end plate)

* Supplied In Accessory Pack.

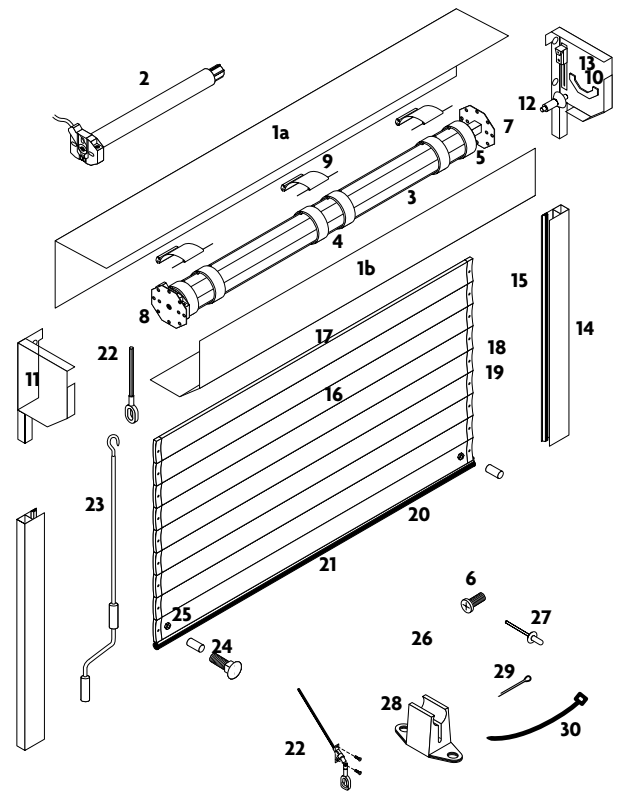

Recommended Fixings (not supplied)
12 x 1" Self Tapping Screws for Steel
12 x 2 1/2" Countersunk Screws for
Masonry and Wood

02. INSTALLATION OPTIONS AND CRITERIA FOR COMPLIANCE WITH LPS 1175: ISSUE 7

Internal installation only

The garage door must be installed internally. If all of the end plate is not fitted above the opening then a 90° fascia must be fitted to the door.

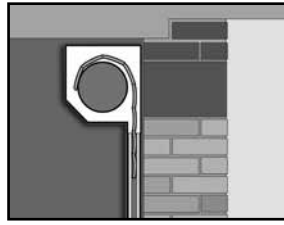

Face fit

If the guide rails are face fitted they must not protrude into the opening and they must be 90mm.

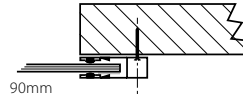

Reveal fit

If the guide rails are reveal fitted they must be 90mm guide rails complete with steel reinforcement plates to protect the base of the guide rails.

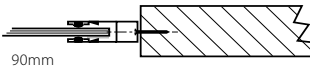

Minimum number of fixings per guide rail

Height of guide rails	Minimum no. of fixings required
Less than or equal to 1000mm	3
1001mm to 1500mm	4
1501mm to 2500mm	5
2501mm to 3500mm	6
3500mm +	7

Proximity of holes to the end of the guide rails

The first and last holes at the ends of the guide rails must be drilled 120mm from the ends of the guide rails.

When the head of the shutter is exposed

5no. penny washers riveted from external side must be utilised to secure the hood when the head of the shutter is exposed within an opening.

5no. Fixings through at either side

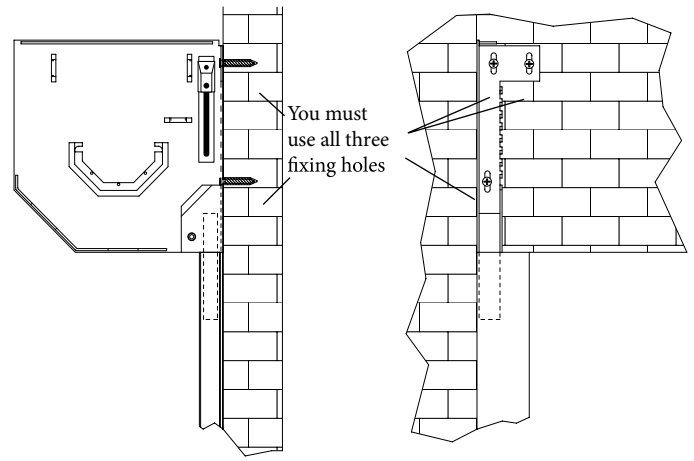
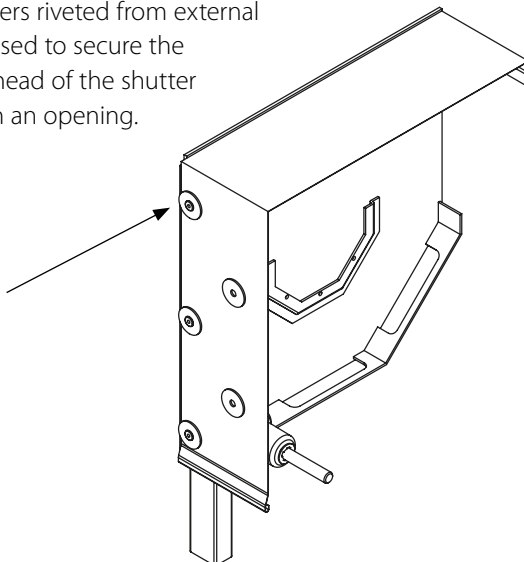

Minimum number of fixings per end plate

All three fixing holes in each end plate must be used

Minimum required fasteners

Brick / Blockwork

No. 12x2" screw with suitable plastic plug

Timber frame

No. 12x2" screw

Steel fixing (any of the following)

- 5 x 25mm Tec screws
- No. 10x1" Pozi Pan head screws
- M8 x10mm hex head or dome head bolts tapped in to the steel work (minimum 5mm thick steel)
- M8 bolts and nuts

All fixing heads must be spoiled for compliance with LPS 1175.

All switches, key switches and remote control equipment must be installed on the inside of the garage for compliance with LPS 1175.

The label supplied, stating the manufacturer, the product, the security rating and the certificate number must be attached to the door.

Please note: The validity of the LPCB certification is contingent upon the roller garage door being installed in accordance with the requirements of LPS 1175.

ALTERNATIVE INSTALLATION OPTIONS (NOT COMPLIANT WITH LPS 1175)

External installation

The door can be installed externally if compliance with LPS 1175 is not required.

Please note the remote control receiver unit and the bottom slat safety edge transmitter must be installed internally and not exposed to the elements.

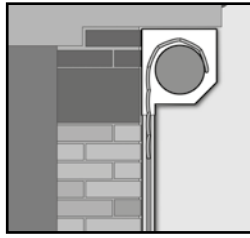
**Face fit**

75mm guide rails can be used if compliance with LPS 1175 is not required.

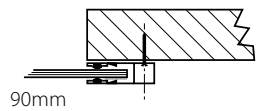
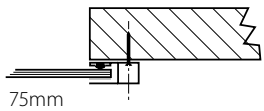
**Reveal fit**

If compliance with LPS 1175 is not required 75mm guide rails can be fitted within the reveal.

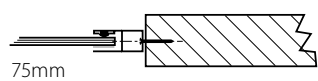
**Combination of face and reveal fit**

In this situation one guide rail is reveal fitted and the other guide rail is face fitted.

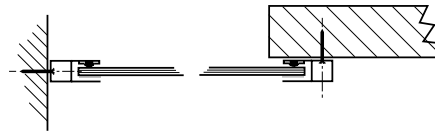
**Undersize face fit**

In this situation the guide rails are face fitted but they will protrude into the opening. This installation will not be compliant with LPS 1175.

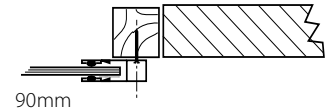
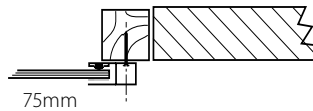
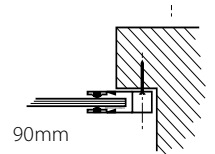
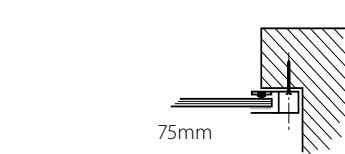

03. PREPARE THE OPENING

Check:

- Structure is sound/even & can carry the weight of the door (curtain weight is approximately 5kg/m² and allow an extra 15kg for the guides, end plates and axle assembly)
- No obstacles in fitting footprint e.g. no sharp objects, pipes, cables, bumps etc. sticking out from the pillars, lintel or header to twist the guides, distort the fascia or catch on the curtain
- Floor is flat/level
If necessary install a sub-frame to ensure secure, flush and level fixing. (Recommended minimum 70 X 70 PAR)

High winds and high temperatures can cause increased deflection of the door. It is the **installer's responsibility** to ensure that the door is packed off the wall sufficiently to allow for door movement during these extreme weather conditions.

04. PREPARE THE GUIDE RAILS

Please note: The validity of the LPCB certification is contingent upon the roller garage door being installed in accordance with the requirements of LPS 1175 (see Section 2 for further details).

If the guides require cutting down refer to the information at the start of Section 1 and also Section 9 for reducing the curtain height. If face fixing where possible set the guide height at least 55mm above the structural opening height to maximise drive through height.

- Position guides

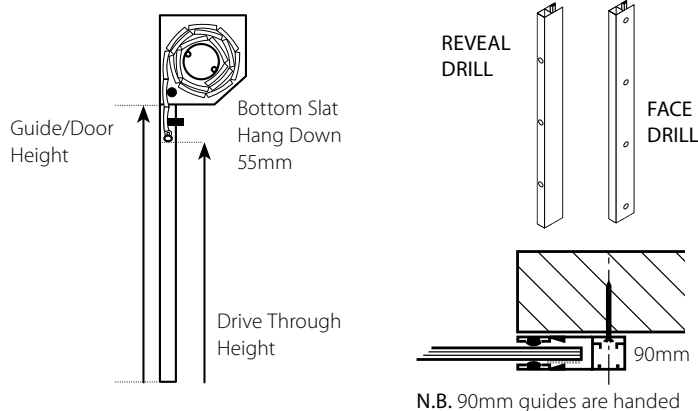

- Drill guide fixing holes, 7mm pilot hole, 13mm outer hole (min 4), avoid mortar joints and edges of bricks etc.

Unless you have opted for pre-drilled guides – Pre-drilling is compliant to the LPCB certificate.

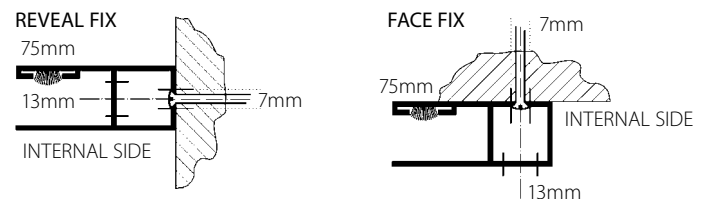

LPS 1175 compliant doors

Doors which are compliant with LPS 1175 will be supplied with a bottom slat anchor system prefitted to the bottom slat and guide rails.

Once the guide rails have been fastened in place the bottom slat anchor guide insert must be fastened to the floor as shown below.

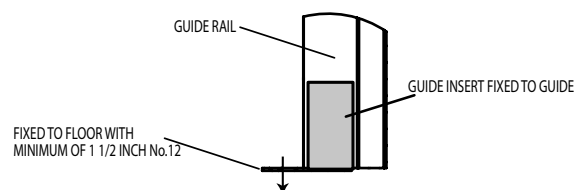

05. FIT END PLATES, AXLE ASSEMBLY, GUIDES (& OPTIONAL FASCIA)

N.B. When fitting doors with 300mm end plates and the guide height is more than 2300mm it is important that you check that the lintel does not bow inwards or have any projections that may catch on the curtain. If in doubt pack the guides and end plates out by at least 10mm.

- i. Slot end plates into guides (and fix optional fascia if supplied) – see **Drawing A**

If using 90mm guides make sure the back face of the end plate is in line with the back of the guide.

3 rivets should be used to fasten the fascia to each end plate. Doors compliant with LPS 1175 will be supplied with penny washers which the rivets must be fastened through.

- ii. Position guides, end plates (& optional fascia) against/in opening
iii. Hold or prop securely in position

Before proceeding any further check:

- a) Back faces of guides and end plates are flush and untwisted – see **Drawing B**
b) That the distance between the outside edges of the guides is 90mm more than the curtain width
c) Ensure that the distance between the outer edges of the end plates is equal to the stated overall width of the door

- iv. Drill fixing holes (minimum of 4 in guides and 2 in each end plate if not LPS 1175 compliant)

- v. Fix guides/end plates with minimum No. 12 x 21/2" countersunk screws (and plugs) to masonry/timber or 12 x 1" self tapping screws to steel.

Fix fascia every metre with minimum 12 x 1" screws. Penny washers must be used to spread fixing load on fascia. If there is nothing to fix to, 50 x 20 box section should be ordered to reinforce the fascia and prevent deflection which may damage the curtain. Drill and pop rivet from inside the fascia ensuring that the rivet leaves a smooth surface

- vi. Ease open top of guides – see **Drawing C**

- vii. The dummy end octagonal fixing plate is supplied in the accessory box

The plate must be fitted to the appropriate end plate (not the motor side) before installation of the axle. Offer up the axle assembly to the end plates inserting the octagonal plate attached to the motor into the end plate mounting bracket and the dummy end/spring shaft into the U cup on the dummy end octagonal fixing plate. Secure the shaft using the 60mm split pin provided.

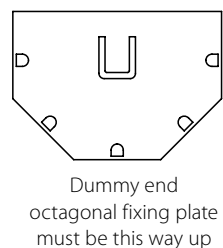
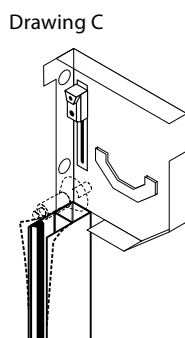
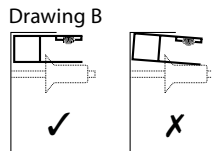
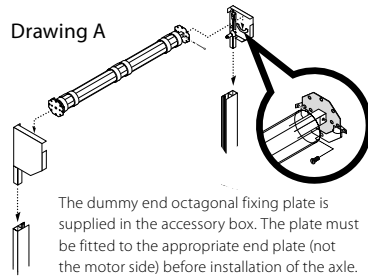

Make sure the motor and override hole are correctly orientated and the limit switches are accessible from below – see motor drawings 1 to 3 – Section 6.

- viii. Secure axle by inserting the No. 8 x 3/8 pan head screws supplied into the holes in the mounting brackets (give the axle a tug to make sure it is securely retained) – see bubble detail **Drawing A**

Lock dummy end shaft securely in place, hard up against the dummy end, with clip provided so as to prevent the axle from moving from its correct position.

Check:

- a) Guides are vertical / parallel / same height and axle is level – see **Drawing D**
b) Collars are the correct way around – see **Drawing F**

N.B. In the event that the screw does not hold, drill a new pilot hole through the mounting bracket and octagonal fixing plate and try again.

For safety reasons it is essential that the fixing plate is secured with three fixings.

- ix. Secure motor POWER LEAD with CABLE TIES so that it is tight against THE end plate – see **Drawing E**

Alternatively you may drill a hole in the end plate to pass the cable through in order to keep it clear of the locking bolt.

N.B. This may not be possible with tight reveal fixes.

You must ensure that you allow for a drip loop in the motor cable to prevent water from running down the cable and into the motor. Spare cable ties can be attached to the motor cable to act as drip loop to prevent water entering the motor.

If an anti-fall back spring has been supplied fitted in the axle you must now tension the spring as follows:

01. Connect the motor to a test lead
02. Remove and retain the limit cover cap from the motor. Fully press in the limit switches on the motor. Using either the test lead or remote control rotate the axle in the close direction (see **Drawing G** and label on axle)
03. The number of turns required will be clearly stated on a label
04. When complete the axle will be fully tensioned and will be ready for installation and attachment of the curtain in the fully closed position

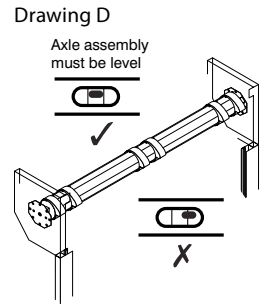

Drawing F

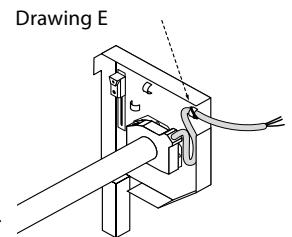
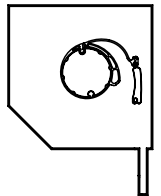

Drawing G

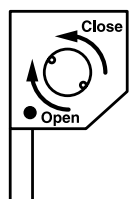

06. FITTING EMERGENCY OVERRIDES

Possible Override Exit Options

N.B. We recommend override exits 1 or 2 shown below as option 3 will be more difficult to operate.

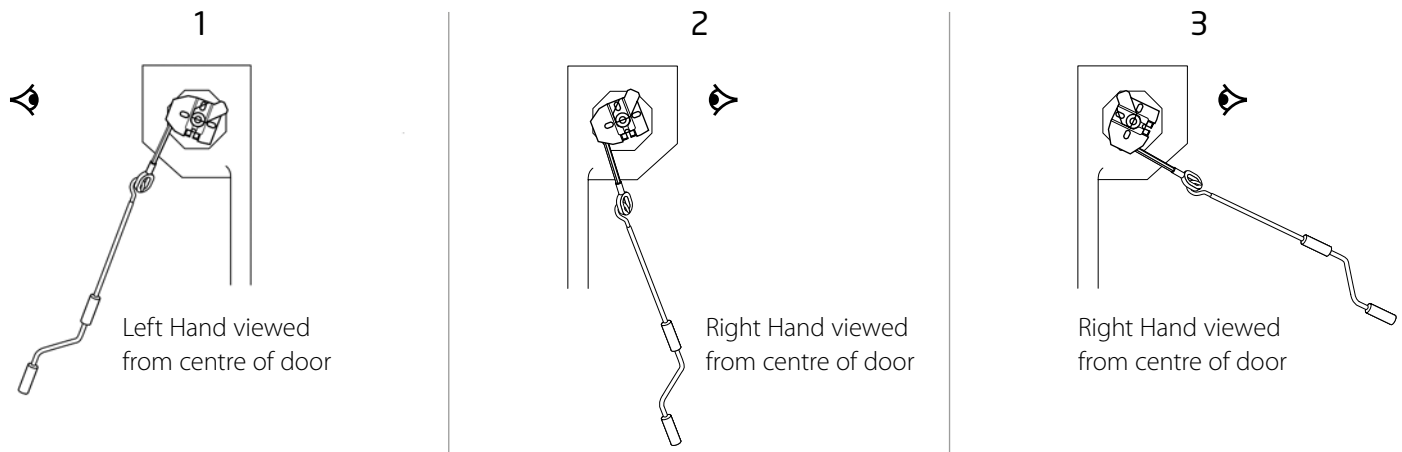

A) Standard Manual Override

If this door has end plates that are not fitted above the opening and it is compliant with LPS 1175 then a plastic tube must be fitted over the rigid eye before it is inserted into the motor and secured in place.

- i. Insert override eye through hole in motor adjacent to limit adjusters
- ii. Insert and tighten the holding screw and washer from above
- iii. Hook crank handle to eye
- iv. Secure clear of shutter with crank handle clip

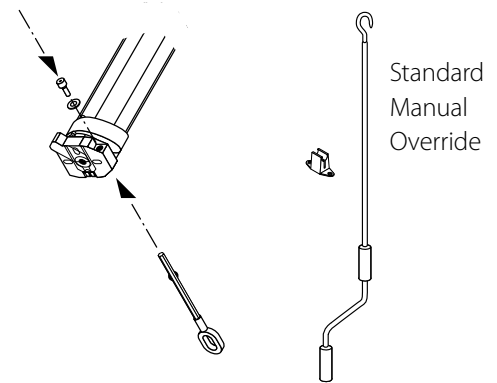

B) Optional external low level override

Detailed installation instructions are supplied in the low level override kit.

The external low level override is not compliant with LPS 1175, a battery backup must be ordered when required.

07. INSTALL THE CURTAIN IN THE GUIDES, ATTACH TO AXLE & FIT STOPS

- i. Check that there are at least 3 pairs of collars on the axle and that they are facing the correct direction – see **Drawing D**.

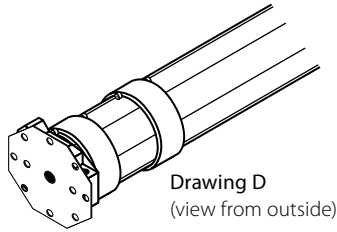

The outside collars **must be** right at the ends of the axle and the third pair in the middle.

If 4 or more pairs are fitted then two of the additional pairs need to be fitted approx. 700mm in from the outside pair. (N.B. the outside collars are held in place by the motor collar at one end and the dummy end at the other. Intermediate pairs will have one collar pre-positioned at the factory with a securing rivet already in place).

Before loading the curtain into the guide rails ensure that the locking blocks are located at the top of the end plate.

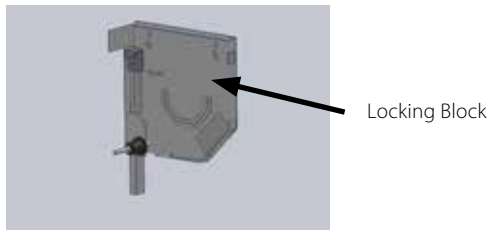

After a door has been installed, during normal operation, the door will settle causing the fully open and fully closed positions to move slightly from the original positions.

Wrap bubble wrap around the axle to protect the curtain and continue with remaining instructions.

- ii. Lift coiled curtain up level with axle and feed bottom of curtain over axle and into guide
- iii. Slowly unroll curtain and gently lower onto a tool box or block
- N.B. Do not allow the curtain to free fall over the axle as this will result in damage to the curtain
- iv. Slide the locking/attachment arms on to the top slat

For the above see **Drawing A**

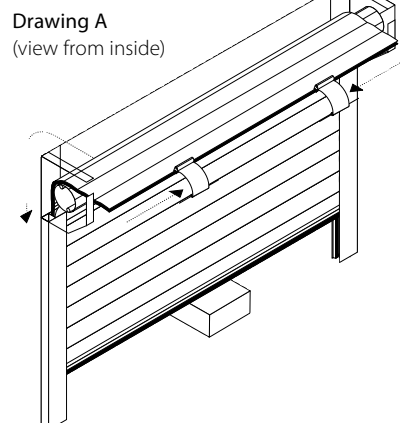

- v. Position unattached end of locking/attachment arm so that the fixing bar lines up with locating holes in the two collars (rotate axle with override if necessary) and slide collars together making sure pre-positioned collar is tight against rivet – see **Drawings B & C**

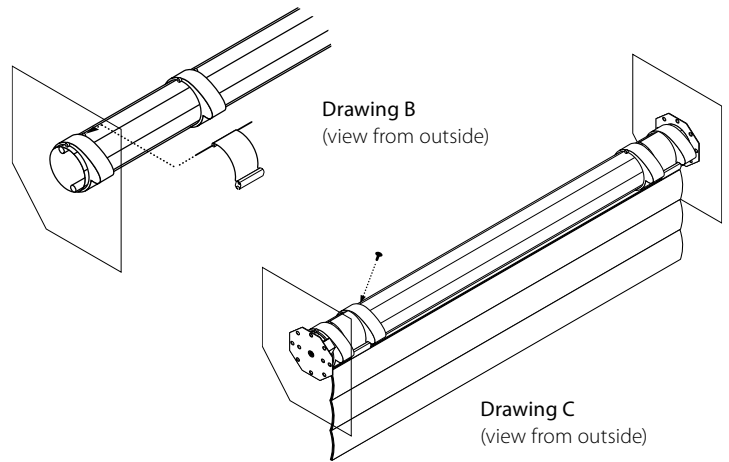

- vi. Fix 'loose' collars in position by placing a 4.8mm x 9.3mm x 12mm pop rivet tight up against the outside edge of the collar in the rounded cut-out in the axle. There is no need to drill a hole – see **Drawing D**

N.B. Make sure rivets are secure

- vii. Use override to raise door sufficiently to remove toolbox/block. Leave door in partially open position

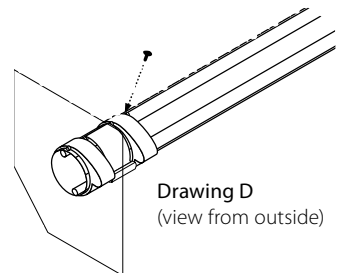

- viii. Secure stops to captive nuts in bottom slat with bolts provided – see **Drawing E**

N.B. It is essential to fit stops for health and safety reasons

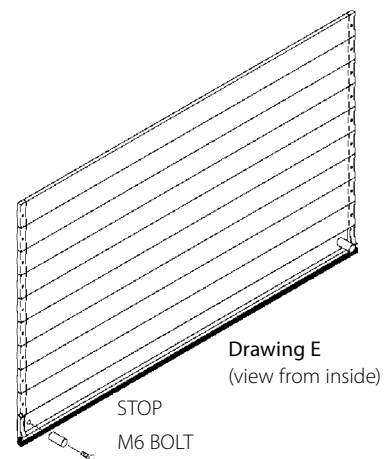

LPS 1175 Compliance

All doors which have been ordered to comply with LPS 1175 will have been supplied with a **silver label** stating the product name, the manufacturer and the security level the door achieved. This label must be attached to the guide rail for the door to be compliant.

08. CURTAIN LOCKING & SETTING MOTOR LIMIT SWITCHES

The roller garage doors are manufactured with the curtain height to suit the length of guide supplied.

The door will not lock down properly if the curtain is either too tall or too short – see **Drawing A & B**.

For Classic and Excel, ensure the locking blocks are in place – refer to locking procedure **Section 7**.

We recommend using a test lead when carrying out this operation. Failure to do this could result in damage or injury.

- Connect the motor cable to a test lead.
- Ensure you follow the correct instructions for the correct motor.
- Drive the axle to the fully closed position.
- Attach the curtain to the axle and fine tune the closing limit. (follow instruction if anti-fall back spring is being used) – see **Drawing B**.
- Drive the curtain to the open position and set the top limit to the fully open position with the bottom slat fully in the in the guide – see **Drawing D**.
- Run the door to test top and bottom limit and connect the motor cable to the receiver unit.

Open/up limit setting

- Send the door up with the test lead to open/up position and stop (50mm of curtain should still be in guide. Stops should be 10mm below fascia – see **Drawing D**).
- Press and release the open/up limit switch.

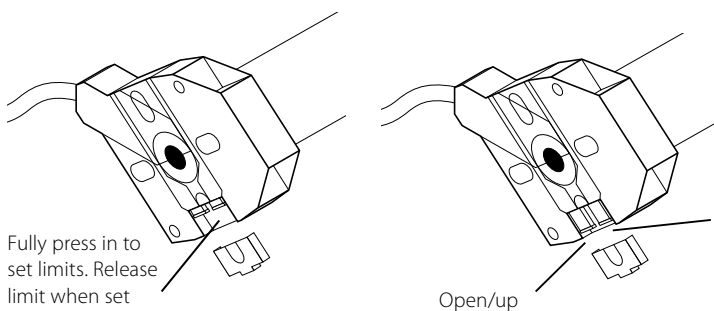

N.B. Always replace the yellow limit switch cover cap once limits are set.

Somfy motor drive only

- Remove the yellow cap and press both buttons inwards.
- Drive the door to the down position.
- If the axle contains an anti-fall back spring then count the amount of turn so it matches the amount written on the sticker on the axle.
- If no springs are present then set the down limit when the axle stops.

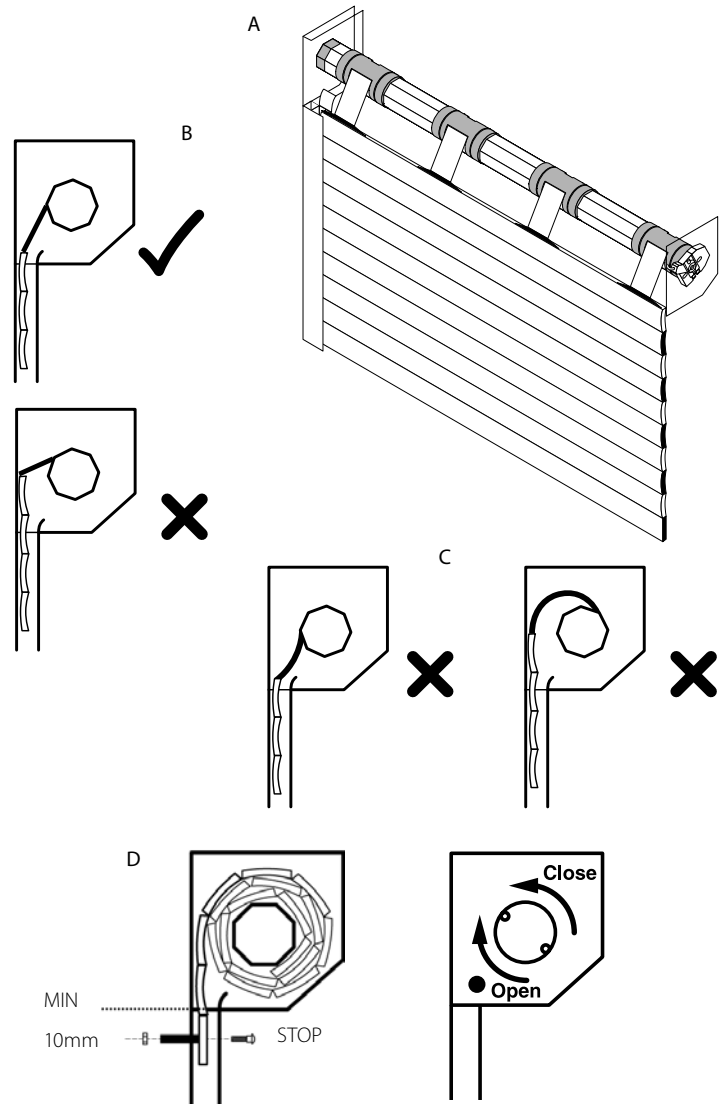

SeceuroDrive motor only

- Using the limit adjusting tool, drive the axle to the fully closed position.
- If axle contains an anti-fall back spring then you must count the amount of turns.
- Look at the number of turns required on the sticker and then add this amount of turns to the downwards action.
- If no springs are present then set the down limit when the axle stops.

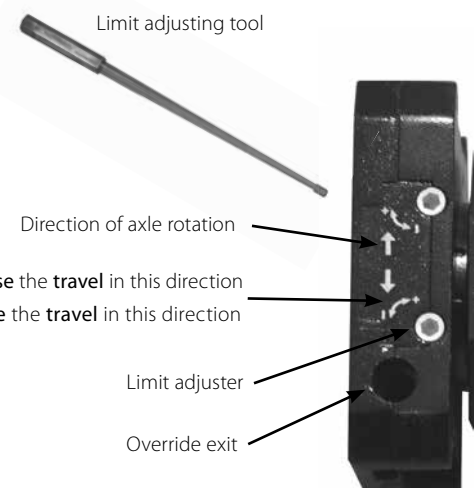

09. CURTAIN ADJUSTMENT (REDUCING HEIGHT/MAKING REPAIRS)

The curtain needs to be the correct height for the door to lock properly (if too tall remove slat(s) – If too short notify supplier). The optimum curtain height finishes midway up the end plate to ensure the locking mechanism engages.

Check you have the correct number of slats in the curtain for the guide height (particularly if you have shortened the guide height) and adjust the curtain accordingly.

Curtain height =

Curtain slats

+ Extruded top slat

+ Bottom slat

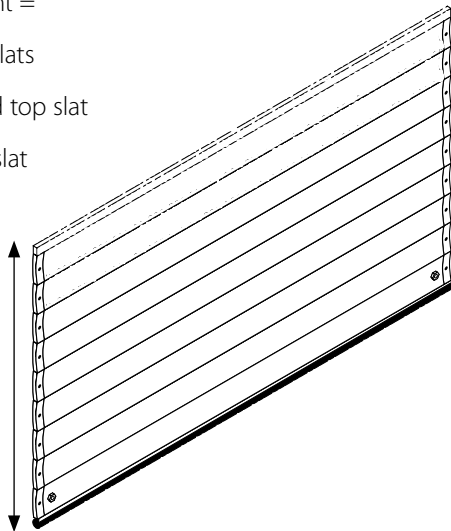

- i. Roll out the curtain on a flat and protected surface, such as bubble wrap and/or cardboard packaging in which the curtain was delivered.
- ii. Unscrew webbing from every slat which needs to be removed or replaced, gently lifting the webbing away from the surface of the slat.

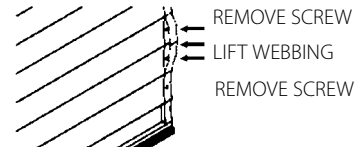

- iii. Slide out damaged slats and replace with new slats. Press down webbing and screw to the new slat.

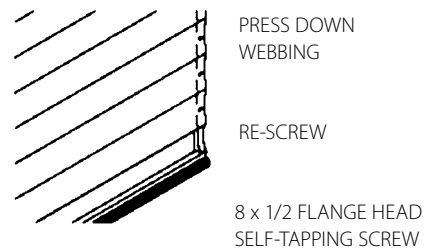
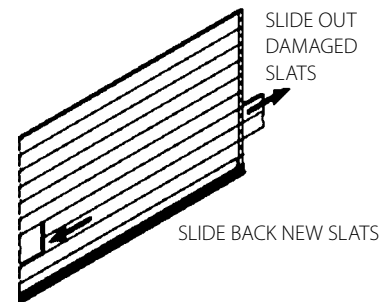

- iv. If the number of slats has been reduced, trim the webbing accordingly and carefully melt the cut ends to prevent fraying.

10. INSTALLATION OF BOX SUPPORTS - OPTIONAL EXTRA FOR HALF BOX OR FULL BOX

The box supports you have been supplied need to be riveted to the fascia to hold them in place.

1

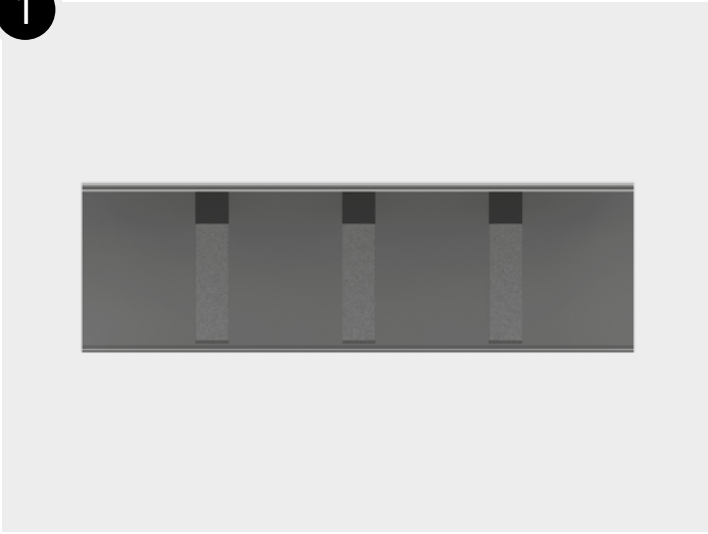

First fix the fascia in place then position the box supports within the fascia with equal distances in between each support.

2

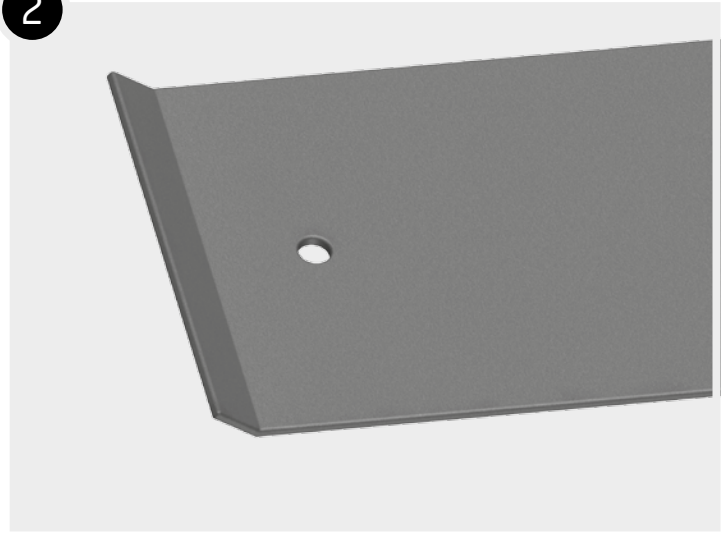

The box supports are supplied with a hole on the top front edge.

3

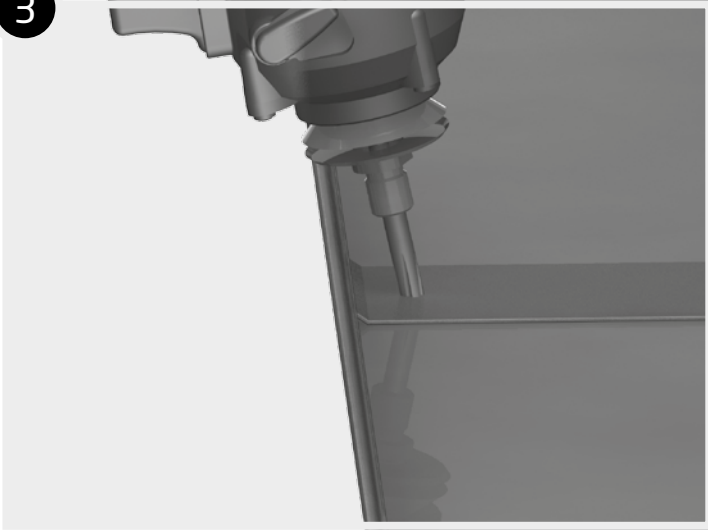

Drill a hole with a 4.2mm drill bit through this hole and the fascia.

4

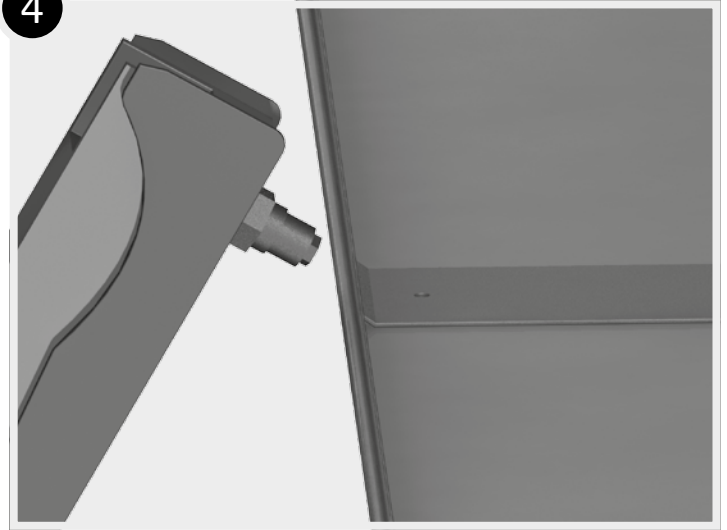

Fasten the box support to the fascia using a 4 x 8 rivet.

11. COMMISSIONING

Internal Fitting

Fit optional 45 degree lid. A slot may have to be cut into the lid to pass over the override eye.

Final Checks

- i. Remove any protective plastic coverings
- ii. Wipe curtain & guides with damp cloth
- iii. Touch-up any small scratches
- iv. Check all electrical & operating equipment is installed and functioning correctly (especially the safety edge) and complete CE marking label and paperwork
- v. Check direction handle needs winding to open door and fit appropriate label supplied to crank handle.
- vi. If the door is fitted externally apply a bead of silicone around the box edge to prevent water ingress.

N.B. Check the front of the curtain to make sure that it is not rubbing on the fascia etc.

The manual override will not function after the door is operated, by remote control, until the power to the motor has 'timed out'.

This will take a few moments to occur.

If you wish to demonstrate the manual override immediately after opening the door press either the stop button on the handset or simulate a power cut by switching off the power to the Control unit.

If a low level external override is fitted or the door is fitted externally remind customers to keep the override handle in a convenient place (not in the garage if no other way in!)

Upon completion it is your responsibility to train the customer how to operate the door correctly and safely and provide them with the operating and maintenance instructions supplied.

12. TECHNICAL ASSISTANCE

If you require any on site technical assistance including repair or maintenance queries please call **01524 772400** or email technical@swsuk.co.uk

Control unit set up instructions are provided in the control panel accessory box along with the control unit and you can also access them digitally using this QR code or link:



www.sws.co.uk/easysetup