

Glazed
industrial
closing
systems

SLIDING glass with lower guide

Single or double sliding door with lower guide



The perimetral frame of each leaf of the sliding door consists of galvanised steel section "L" (dim. 60x80mm) tubular profiles and mounting of galvanised steel section "T" (dim. 60x50mm) tubular profiles. The finishing consists of textured painting colour similar to RAL of embossed finishing. Windowpanes in different type of glass (laminated, insulating, security glass, transparent, tinted glass) with maximum thickness up to 40mm. Glazing bead having metal section secured against the edge of a glass pane to hold it in place and textured paint finishing colour similar to RAL.

The upper guide, fastened onto the wall (lintel) or under the ceiling, consists of steel anchor and pressed and bent galvanised steel profile designed according to our drawings, equipped with trolleys and bearings and covered by a steel pre painted covering sealed on the top. In the lower tubular of the perimetral frame of sliding door panel, there are steel wheels. The upper and bottom sealing is granted by nylon brushes held by a stainless steel profile. The bottom rail consists of "U" shape galvanized steel profiles designed under our technicians' supervision and provided with distance regulators in accordance with the wheelbase of the door (the lower guide has to be installed on Customer's charge).

Cremones (cremone bolts) and aluminium handles painted in black colour are installed on the internal face of door panels at eye level. Cremones are designed to grant 4 points of closure and central friction. A vertical galvanized steel flush bolt (tower bolt) is provided with two die-cast brass rods to grant two points of closure. In order to assure an easy sliding, all strike plates are internally covered by Teflon.

In case the door is provided already motorised, a security control micro is installed to avoid an uncontrolled door opening and consequently problems at the motor.

The perimeter wing gasket consists in EPDM rubber (anti-aging) in order to assure strong closure between wings. The space between wings consists in 50mm. (anti-crushing) for all versions: manual, motorized or arranged for the motorization according to the law.

Working temperature: -30°Celsius; +70°Celsius

Windload resistance directive CE EN13241-1, windload class resistance 3

Thermal transmittance 13241-1 U=1,6W/sqm.K.



w e o p e n y o u r f u t u r e



Single or double sliding door with lower guide

Glazed industrial closing systems

CROSS SECTION STANDARD FASTENING

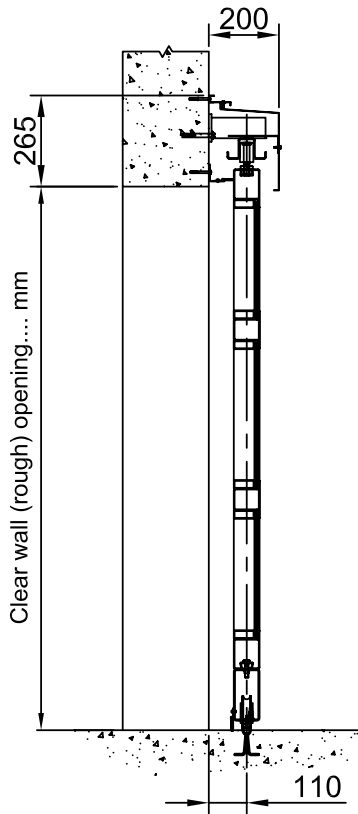

Detail of the upper guide

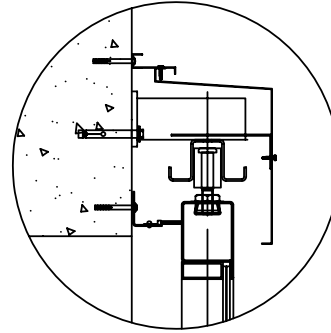

Detail of the lower guide

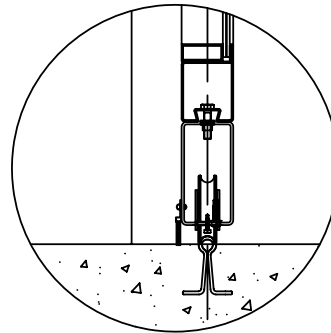

PLAN SECTIONS

Sliding door (single acting leaf) with bottom guide

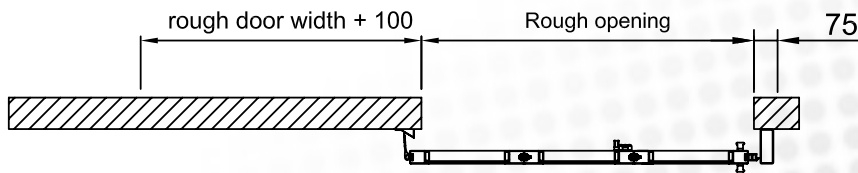

Sliding door (double acting leaf) with bottom guide

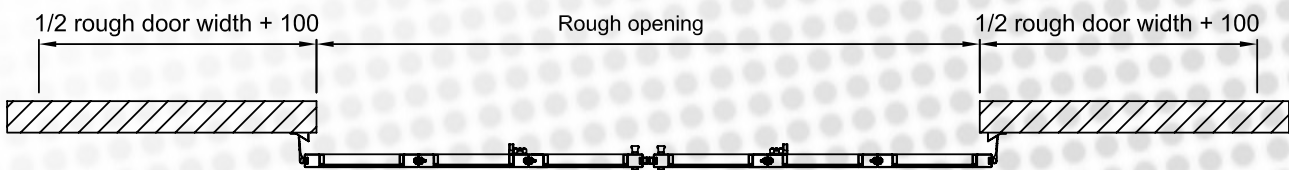



Single or double sliding door with lower guide

Glazed
industrial
closing
systems

O P T I O N A L

- Pedestrian door with or without threshold (wicket door)
- Fixed insulated panels covered with pre-painted sheet
- Louvred panels
- Glazed panels (possible different characteristics)
- External tower bolt with lock and lever
- Possible RAL painting for door frame
- Tubular beam
- Automation (motor) according to the law

Machinery directive compliance 98/37/CE

Directive for low voltage tools compliance 73/23/CEE

Electromagnetic compatibility directive compliance 89/336/CEE

EN 12445, safe use for motorised door. Test.

EN 12453, safe use for motorised door. Requirements.

