

Industrial  
insulated  
closing  
systems

## SLIDING with lower guide

Single or double acting sliding door with lower guide



Sliding door consists of 52mm thick panels. Each panel has face sheets of light-gauge steel ( 20/10 galvanised steel SENDZIMIR ), pre-painted white colour / grey similar to RAL 9002 on both faces and bonded to a galvanized steel channel frame reinforced with a rigid plastic-foam core. Sheets are obtained from an initial continuous lamination process, following a phosphate process and a final Primer paint (5 Micron thickness) on both sides of sheets. The finishing consists in 20 Micron thick paint applied on the external side of the sheet. So that the surface is totally smooth. The pre-painting finishing provides 400 hours of resistance in the saline fog atmosphere room without any alteration. In order to avoid any possible scratch, an adhesive film is applied on and to be removed once the door is assembled. The thermal insulation is assured by the injection of auto-extinguishing polyurethane foam according to standard DIN 4102 class B2 of 43/45 Kg./m<sup>3</sup> density. The polyurethane foam provide high resistance to heat flow thanks to the press process.

The upper guide, fastened onto the wall (lintel) or under the ceiling, consists of steel anchor and pressed and bent galvanised steel profile designed according to our drawings, equipped with trolleys and bearings and covered by a steel pre painted covering sealed on the top. In the lower tubular of the perimetral frame of sliding door panel, there are steel wheels. The upper and bottom sealing is granted by nylon brushes hold by a stainless steel profile.

The bottom rail consists of "U" shape galvanized steel profiles designed under our technicians' supervision and provided with distance regulators in accordance with the wheelbase of the door (the lower guide has to be installed on Customer's charge).

Cremones (cremone bolts) and aluminium handles painted in black colour are installed on the internal face of door panels at eye level. Cremones are designed to grant 4 points of closure and central friction. A vertical galvanized steel flush bolt (tower bolt) is provided with two die-cast brass rods to grant two points of closure. In order to assure an easy sliding, all strike plates are internally covered by Teflon.

In case the door is provided already motorised, a security control micro is installed to avoid an uncontrolled door opening and consequently problems at the motor.

The perimeter wing gasket consists in EPDM rubber (anti-aging) in order to assure strong closure between wings. The space between wings consists in 50mm. (anti-crushing) for all versions: manual, motorized or arranged for the motorization according to the law.

Color: standard Grey similar to RAL 9002

Working temperature: -30°Celsius; +70°Celsius

Reference norm CE EN 13241-1 (CPD), class resistance wind 3.

Thermal transmittance according to 13241-1 U=1,6W/sqm.k



w e o p e n y o u r f u t u r e



## Single or double acting sliding door with lower guide

Industrial insulated closing systems

CROSS SECTION STANDARD FASTENING

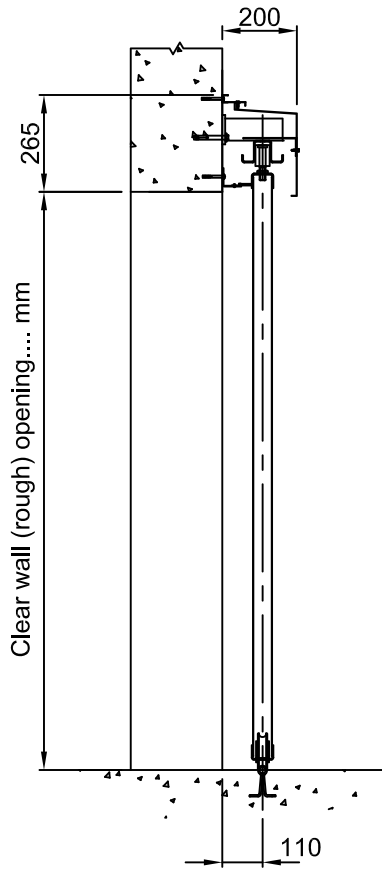

Detail of the upper guide

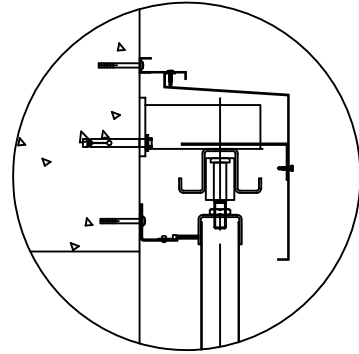

Detail of the lower guide

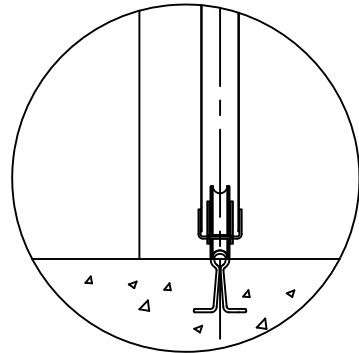

PLAN SECTIONS

Sliding door (single acting leaf) with bottom guide

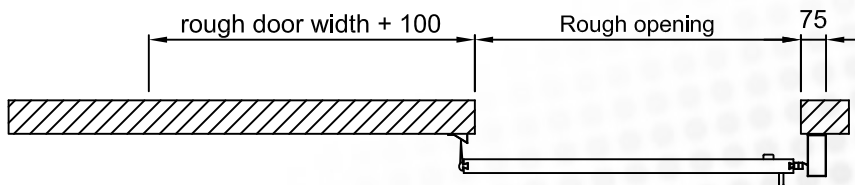

Sliding door (double acting leaf) with bottom guide

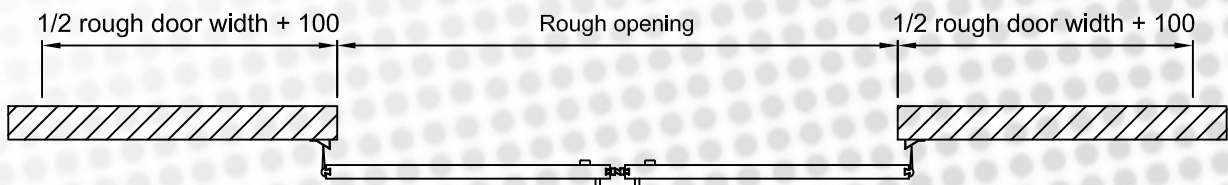



### Visual lights with safety glass 5+5 Visarm and sealing in EPDM gasket

500 X 500  
500 X 700  
500 X 1000  
600 X 1200  
700 X 700  
700 X 1000

### Visual lights with aluminium frame and 5+5 Visarm glass or double-glass. Different finishing

500 X 500  
500 X 700  
500 X 1000  
600 X 1200  
700 X 700  
700 X 1000

### O P T I O N S

- Pedestrian door with or without threshold (wicket door)
- Fixed panels
- External tower bolt with lock and lever
- Louvred panel
- Tubular beam
- Stainless steel finishing
- Available colors in pre-painted metal sheet:  
Grey/White RAL 9016, White RAL 9010, Dark Grey RAL 7016, Silvery Grey RAL 7001, Grey Aluminum RAL 9007, White Aluminum RAL 9006, White/Grey RAL 9002, Brown RAL 8028, Dark Brown RAL 8019, Green RAL 6002, Green RAL 6005, Blue RAL 5010, Blue RAL 5009, Red RAL 3000, Ruby Red RAL 3003, Yellow RAL 1021.
- Possible RAL painting
- Automation (motor) according to the law

*Machinery directive compliance 98/37/CE*  
*Directive for low voltage tools compliance 73/23/CEE*  
*Electromagnetic compatibility directive compliance 89/336/CEE*  
*EN 12445, safe use for motorised door. Test.*  
*EN 12453, safe use for motorised door. Requirements.*

