



SeceuroDoor Industrial Doors  
For Distribution Depots

## Installation Options for SeceuroDoor Industrial Door

As standard this product is designed for face fit installations only around the opening. Price available on application for when doors need to be fitted within the opening.

We are able to offer four variations of guide angle arrangement, the appropriate solution will depend on the structure the product is being fitted to and the application.

Order forms are available for each arrangement type.

Arrangement	Guide angle attached to end plate	Guide angle inset or outset
Face fix	No	Outset
Flag	Yes	Outset
Flag inset	Yes	Inset
Closed steel	No	Inset

## Guide angle arrangement diagrams

See **Page 10** for more information.

# Guide angle arrangement diagrams

## for SeceuroDoor 3 Phase Shutters

### Face Fix arrangement (default)

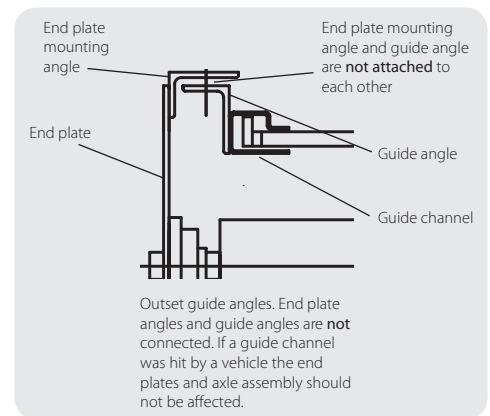
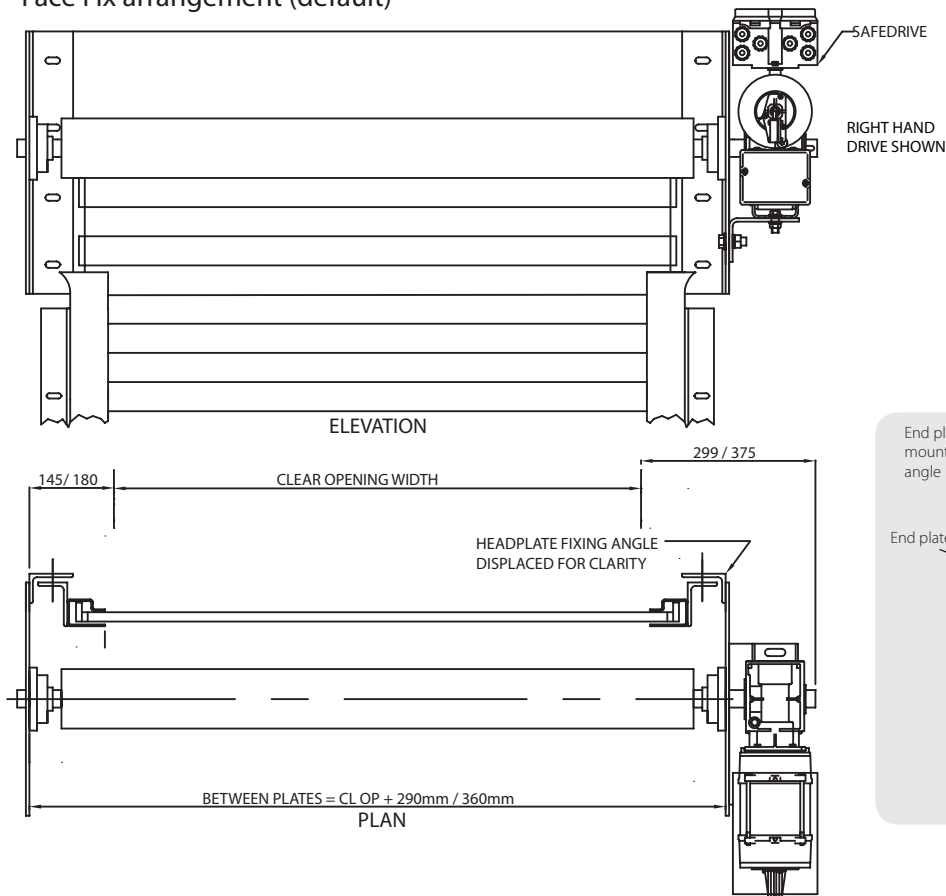

### Flag Guide arrangement inset angle (no surcharge)

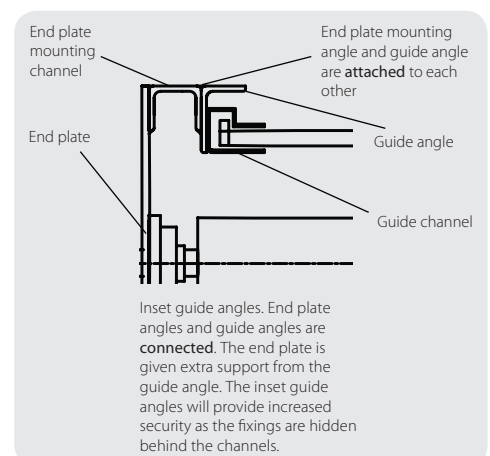
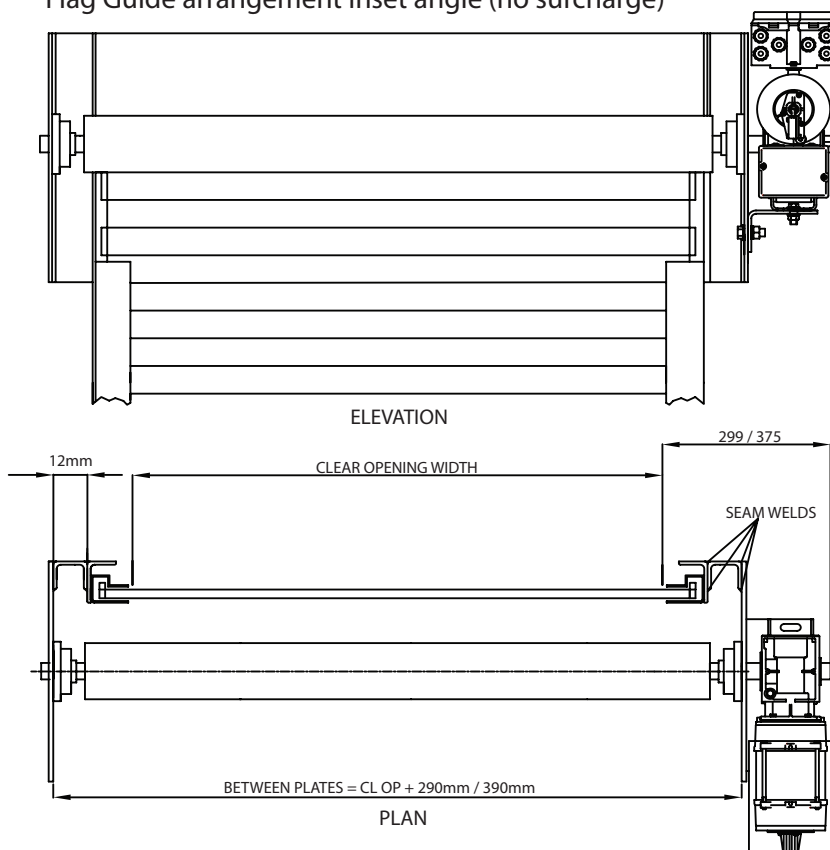

### Flag Guide arrangement (no surcharge)

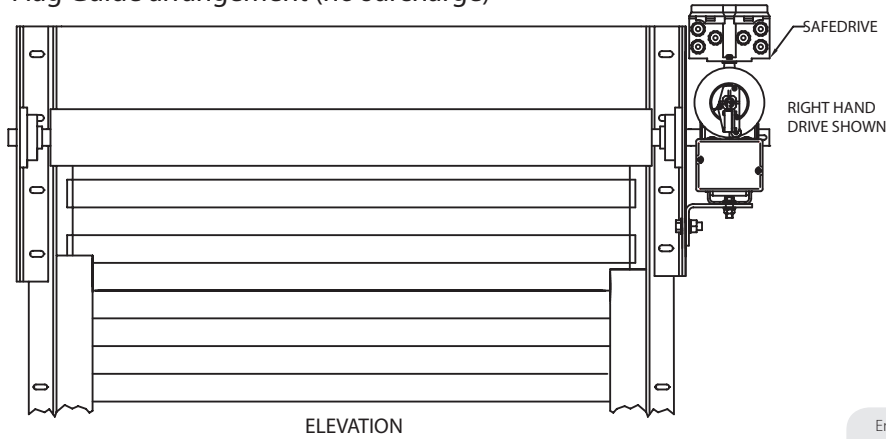

ELEVATION

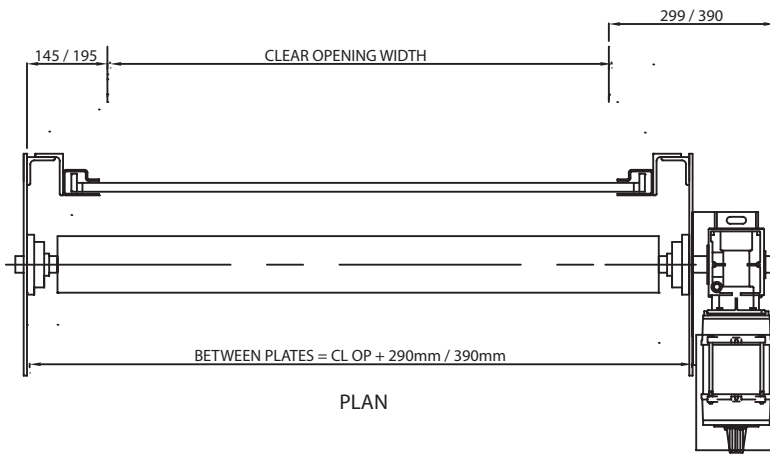

PLAN

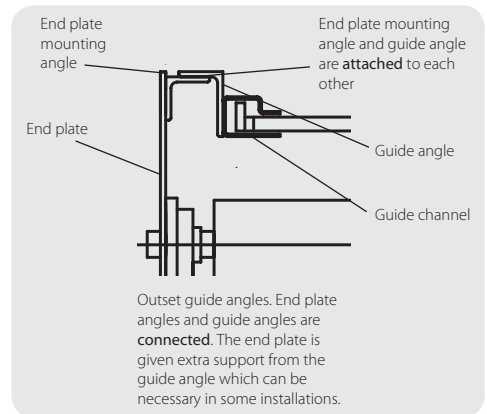

### Closed Steel arrangement (surcharge)

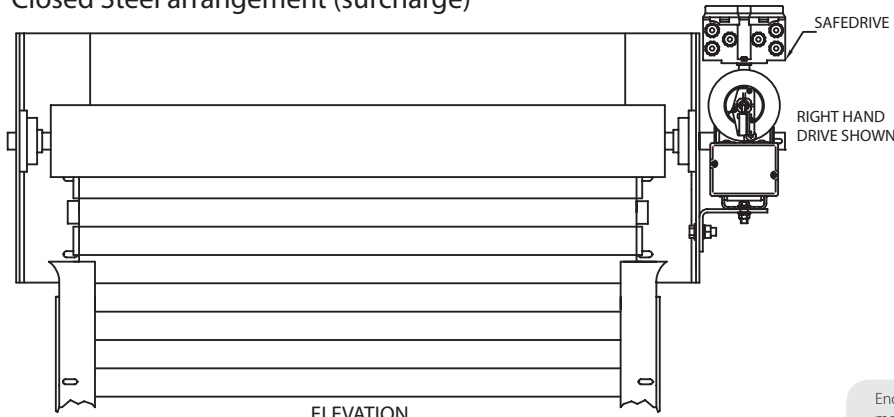

ELEVATION

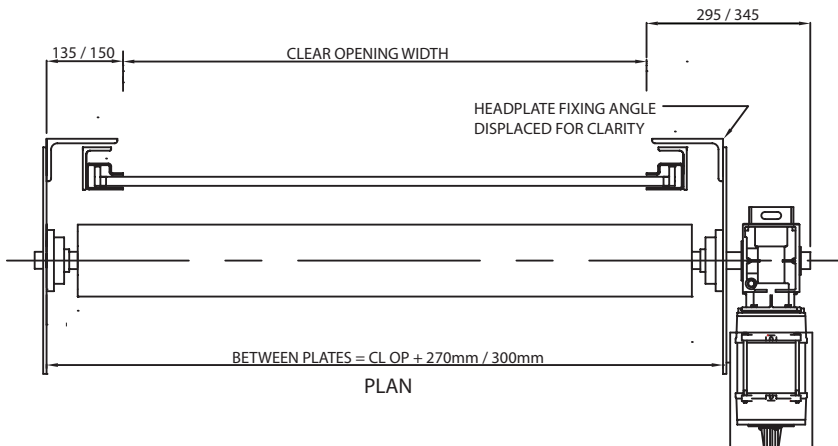

PLAN

