

English



Important notes for specialist retailers and end users

Please read carefully before using!

These instructions must be kept by the end user

1. Contents

1. Contents	2
2. Reading the Maintenance Instructions and Directions for Use.....	3
2.1 Validity of these instructions	3
3. Safety notes	4
3.1 Fundamental safety notes	4
4. Description of construction and function	4
5. Maintenance.....	5
5.1 Cleaning	5
5.2 General cleaning guidelines	5
5.3 Cleaning powder-coated aluminium parts and profiles.....	5
5.4 Cleaning the glass panels.....	5
5.5 Cleaning the water drains	6
5.6 Important guidelines for the winter season	8
5.7 Maintenance work	8
6. Directions for use	9
7. Engineering/production-related features	10

2. Reading the Maintenance Instructions and Directions for Use

These instructions are geared towards trained fitters and require knowledge of installation techniques. Terrazza roofs may only be installed by specially qualified personnel with corresponding installation experience.

Unless otherwise stated, these maintenance and directions for use always presume that the Terrazza is shown from the following angle:

Figure 1: View template

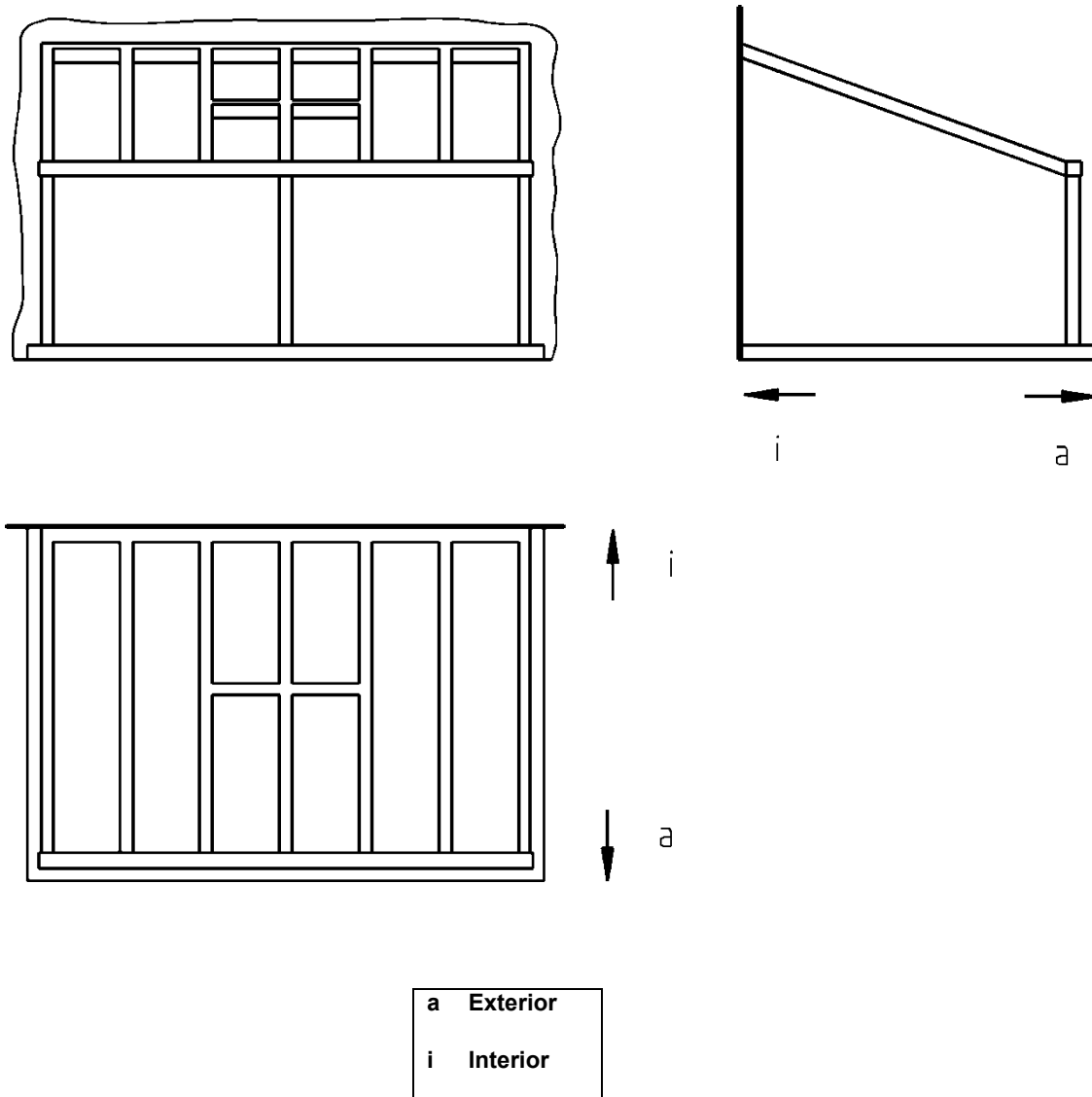

2.1 Validity of these instructions

The weinor roof has been approved for export and Germany.

3. Safety notes

- The assembly and operating instructions must be read and observed.
- Observe the corresponding accident prevention regulations.
- Ensure when installing the Terrazza that all existing electrical connections are disconnected.
- Cordon off a large space around the installation site.
- Check that all scaffolding and building facilities are duly safe and secure.
- Observe the stipulations relating to dowels and fixing materials.
- Only work with fully intact and appropriate tools.
- Keep plastic sheeting, packaging material and small parts away from children – risk of suffocation!
- For personal safety, it is important that these instructions are complied with.
- Non-compliance means the manufacturer does not carry any liability.
- The customer must retain all instructions, and if the product is sold, they must be given to the new owner.

3.1 Fundamental safety notes



Personal injury

Risk of personal injury due to improper use of the Terrazza.

Please read and observe the safety notes contained in this section.



Product and property damage

Risk of damage to the product and property due to improper use of the Terrazza.

Please read and observe the safety notes contained in this section.

4. Description of construction and function

Only high-quality low-corrosion or corrosion-resistant materials are used in the Terrazza. The profiles are made of extruded aluminium. All connecting parts, such as screws, are made of stainless steel. All outside aluminium parts are powder coated.

5. Maintenance

5.1 Cleaning

- Clean aluminium parts and aluminium profiles
- Clean the glass panels
- Clean the water drains
- Guidelines for winter months
- General cleaning guidelines

5.2 General cleaning guidelines

Acids and aggressive cleaning agents such as abrasives, steel wool, scouring pads and knives/blades, as well as solvent-based cleaners (thinner, benzene) are not suitable cleaning materials and may cause irreparable damage.

All regulations relating to accident prevention, environmental compliance and sealing off the immediate surroundings must be observed at all times.

Never use pressure washers. Pressure washers can damage rubber seals and seals around on-site connections or cause them to pop out.



Damage to the product

Particularly in saltwater areas, there is a possibility that salt may disperse or accumulate on the product.

- ▶ **Wash off any salt deposits at regular intervals or as required, but no less than twice a year.**
Recommendation: Call in a specialist company to do the work for you.
This is a good way to protect the aluminium parts and their surface from being corroded by salty water.

5.3 Cleaning powder-coated aluminium parts and profiles

- So that you may enjoy your Terrazza for many years to come, we recommend that you clean the aluminium profiles at least once a year – and even more often if heavily soiled.
- To do so, use plain water only, which may also contain minor amounts of pH-neutral or very weakly alkaline detergents.

5.4 Cleaning the glass panels

- Use ample amounts of clean water to avoid dirt particles scratching the surface.
- Use neutral cleaning agents as far as possible to clean the glass panels.
- Do not use sharp objects to clean the glass panels as these may damage the glass.
- In the case of sand-blasted glass surfaces (e.g. satin glass) with or without anti fingermark finish (special surface coating), clean the glass using clear water and a soft cloth only. The use of aggressive alkaline-based or acid-based cleaning agents will result in damage to the anti fingermark finish.

5.5 Cleaning the water drains

To ensure proper water drainage, make sure that all water drains have been cleared of coarse dirt and foreign bodies. Also clear any snow and ice in winter.

Figure 2: Cleaning

A Remove dirt from the drains

On custom-shaped roofs, non-rectangular roofs or on roofs with sloping guttering especially, check the flow of the water drain from the roof's surface to the guttering and keep it clear at all times.

Figure 3: Cleaning a customised roof

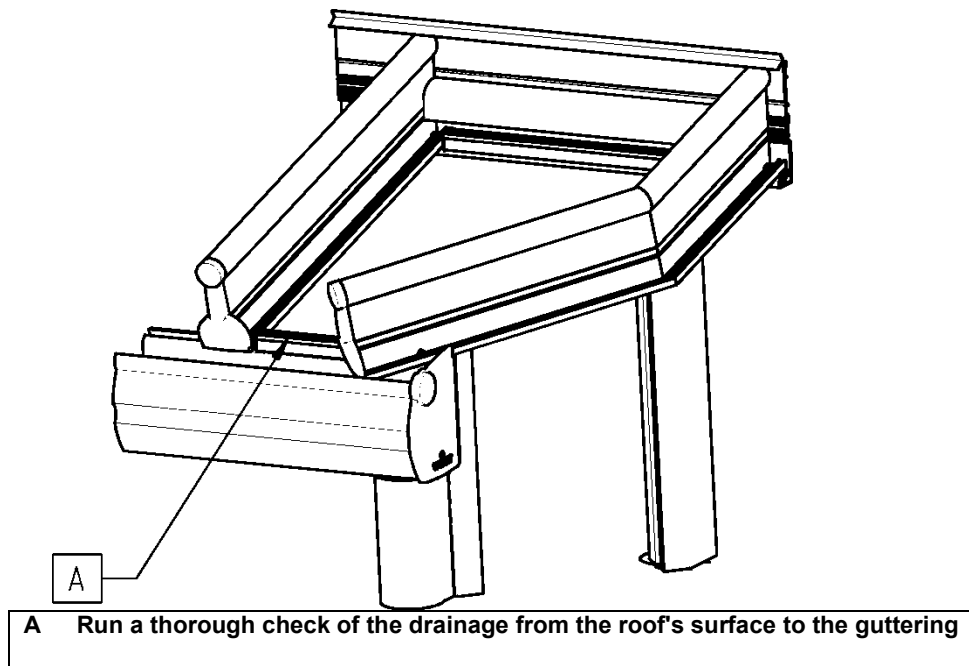
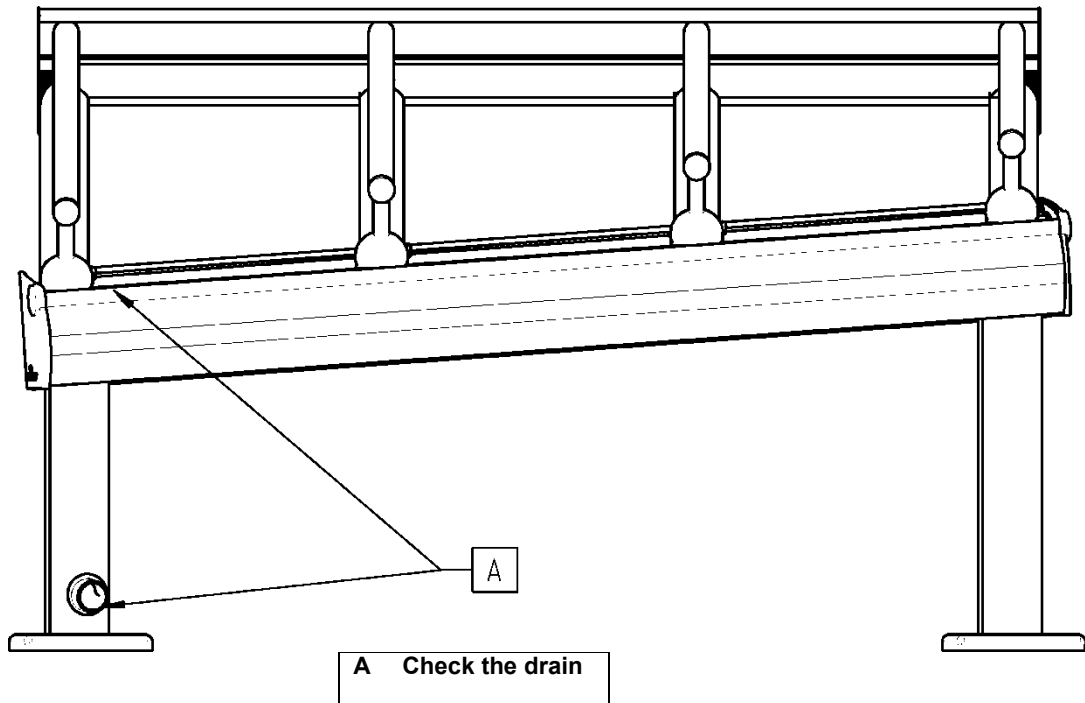

Figure 4: Cleaning sloping guttering 2



5.6 Important guidelines for the winter season

- During wintry conditions and snowfalls, and when temperatures fluctuate around freezing point, you may find snow has settled and/or ice has formed on inner and outer parts or inside the bottom guide profile, which may result in leafs, locks or catches freezing and you being unable to use these parts. These are not product deficiencies. In the worst-case scenario, the unit will no longer open.
- To restore the parts in question to full operability, you will need to free them from any snow and ice in the proper manner.
- On custom-shaped roofs (non-rectangular roofs), snow or ice deposits may result in the roof becoming deformed. Be sure therefore to remove these snow and ice deposits at all costs.

Figure 5: Removing avalanching snow

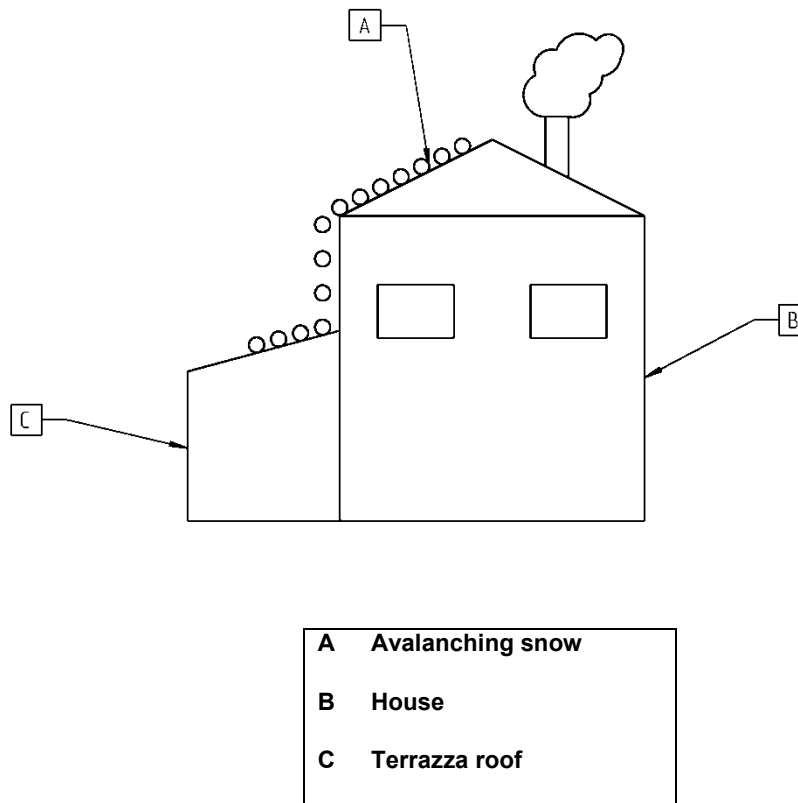

The Terrazza is not designed to withstand extreme snowfalls or avalanching snow. Snow must be cleared from the roof's surface.

5.7 Maintenance work

Only ever clean the Terrazza. All maintenance work should be left to specialists.

- Check the ventilation and awning systems and adjust if necessary
- Inspect the heating system
- Check the electronics and control units
- Touch up/repair any damage to the paintwork on the aluminium profiles
- Check that all rubber gaskets and permanently elastic seals are correctly positioned
- Check the grouting and repair if necessary
- Check all gaskets, seals, etc. between the Terrazza and the on-site connections, and repair as necessary

6. Directions for use

Moisture (condensation) may become noticeable on closed roofs, e.g. roofs with fitted glazing elements. Condensation is not necessarily an indication of errors in the construction itself or the materials used. In most cases, it occurs due to a lack of ventilation. The higher temperature inside the Terrazza causes more moisture to accumulate on the inside than on the outside. As the temperature drops, e.g. during the night, the moisture turns into condensation, initially forming on the coldest surfaces. As a rule, front and corner areas are the first to be affected. If this is allowed to persist, mildew or mould may form as a result. People, plants, adjacent rooms, or adjoining buildings are all possible sources of moisture. Please therefore ensure there is sufficient ventilation, including in critical areas, such as corner posts or behind furniture.

The Terrazza is a non-thermally-insulated structure. As a result, the interior may become very hot when the Terrazza is exposed to high outside temperatures or lots of sunlight, or may turn very cold in the winter or when the outside temperature is low.

7. Engineering/production-related features

As with all industrially produced products, weinor Terrazza roofs may also contain unavoidable blemishes, which must be accepted for what they are. You may rest assured that we constantly seek to provide the best possible quality and keep enhancing it. The types of blemishes that may arise include:

Feature	Potential cause	Remedy		
		How?	By	See
Creaking noises in the guttering or roof support	Different materials expand differently when warm. This may result in an audible creaking sound.	None, as the expansion is unavoidable.	/	/
Condensation on glass panes	Condensation forms as a result of water vapour in the air dripping onto cold surfaces when the air is below its so-called dew point temperature.	Cannot be remedied The possibility of condensation occurring cannot be excluded. The amount of condensation can be reduced by: Airing Heating <u>Change of use</u>	EC	6.1
Tiny air bubbles in glass	Minor quantities of air have been trapped in the glass during production and show up as bubbles.	Cannot be remedied A visual assessment is generally made in accordance with the guidelines of the respective national associations and/or the manufacturers.	/	/
Minor scratches in the glass	Production tolerances	Replace the panes/leaves A visual assessment is generally made in accordance with the guidelines of the respective national associations and/or the manufacturers.	R&P	/

Feature	Potential cause	Remedy		
		How?	By	See
Pimples on powder-coated parts	Minor accumulations have arisen while powder coating the parts.	Cannot be remedied A visual assessment is generally made in accordance with the guidelines of the respective national associations and/or	/	/
Minor deviations in the colour of powder-coated parts	Despite using the same RAL colours, there is always a possibility of two parts being slightly different in colour. This especially occurs when using metal or iron effect paint.	Cannot be remedied A visual assessment is generally made in accordance with the guidelines of the respective national associations and/or the manufacturers.	/	/
Minor scratches on powder-coated parts	Production tolerances	Touch-up pen A visual assessment is generally made in accordance with the guidelines of the respective national associations and/or	R&P/E C	/
Flash rust, pollutants	Particles in the air settle on the unit's components, resulting in minor traces of corrosion.	Treat with water and/or standard household stainless steel cleaners	EC	5.6
Legend: R&P - retailers and partners EC - end customer				

The logo for Weinor, featuring the word "weinator" in a white, lowercase, sans-serif font. A small white circle is positioned above the letter 'i'. The logo is set against a solid red rectangular background.

weinor GmbH & Co. KG
Mathias-Brüggen-Straße 110
50829 Cologne (Germany)
www.weinor.com
Hotline: +49(0)221/5 97 09-214
Fax: +49(0)221/5 97 09-898